

# Case Study

# Abrasive Perforating

Abrasive Perforating System sets 72 Stage Record  
Case Study No. 3204

## DETAILS:

<b>Location:</b>	Oman
<b>Casing Size:</b>	4-1/2" 17#
<b>Conveyance:</b>	2.00" Coiled Tubing
<b>Operation Depth:</b>	15,776' (4,809m)
<b>Well Orientation:</b>	Vertical
<b>Fluid:</b>	2% KCL
<b>Tools Used:</b>	3.06" Abrasive Perforating Assembly 2.88" High Velocity Wash Nozzle

## RESULTS:

Thru Tubing Solutions deployed their patented **Abrasive Perforating System** to complete three zones for a customer in Oman. The last zone was completed in a single trip utilizing a 3-1/16" **NitroTuff Abrasive Perforator** to perforate all 72 stages spread across 35.5m with 0.5m spacing between each stage. The perforator, configured with 5 shots at 60° spiral phasing, created a total of 360 perforations in 11 hours. This operation set a TTS record for the number of perforated stages made in a single run.

## HIGHLIGHTS

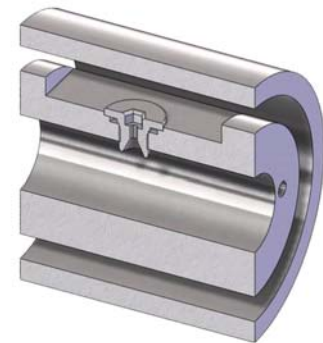

- Alternative to TCP Guns
- Record Setting Job
- 360 Perforations Made
- Single Run Operation

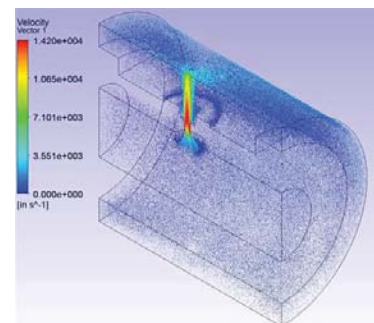

**DON'T LET JUST ANYONE TAKE ON YOUR DOWNHOLE CHALLENGES.**  
DEMAND THE BEST. DEMAND TTS. [WWW.THRTUBING.COM](http://WWW.THRTUBING.COM)