

Mission Statement

Thru Tubing Solutions is a company dedicated to the coiled tubing and snubbing industry. We are committed to providing excellent service to the oilfield industry, specializing in working downhole tools under pressure during various fishing and drilling operations. Our commitment to you, the customer, is a solutions based company with safety and service our primary goals.

Engineering Solutions

Thru Tubing Solutions' engineering department has developed a complete line of snubbing and thru tubing tools including a patented sealed bearing mud motor.

Our engineering capabilities allow quick response time for "hot jobs", providing custom engineered products available to field operations - often with same day results.

Thru Tubing Solutions' quality inspection facility maintains conformity of all manufactured equipment. We also have equipment to test performance and metallurgy specifications to ensure our customers always receive the best equipment in the industry.



Company Locations

www.ThruTubing.com
Email: ttsinfo@thrutubing.com

Corporate Headquarters

2033 N. Main Street
Newcastle, OK 73065
405-692-1900 (office)
405-692-1911 (fax)

United States

COLORADO

600 17th Street
Suite 2800 South
Denver, CO 80202
303-563-5310 (office)

LOUISIANA

1157 Aillet Road
Broussard, LA 70518
337-289-9696 (office)
337-289-9416 (fax)

NORTH DAKOTA

4920 N. Broadway
Suite 1
Minot, ND 58703
701-839-0167 (office)
701-839-0178 (fax)

OKLAHOMA

1501 E. 20th Street
Elk City, OK 73644
580-225-6977 (office)
580-225-7077 (fax)

225 SW Haileyville Ave
McAlester, OK 74501
918-429-7700 (office)
770-308-7192 (fax)

PENNSYLVANIA

100 S. Campus Drive
Imperial, PA 15126
412-787-8060 (office)
855-256-5379 (fax)

2355 Route 442 Highway
Muncy, PA 17756
570-546-0323 (office)
570-546-2331 (fax)

WYOMING

371 Blairtown Road
Rock Springs, WY 82901
307-382-5744 (office)
307-382-5733 (fax)

313 North American Ave #1
Cheyenne, WY 82009
307-632-7734 (office)
307-632-7748 (fax)

TEXAS

6769 Interstate Highway 37
Corpus Christi, TX 78409
361-883-4600 (office)
361-883-4602 (fax)

5175 Whitehurst Drive
Longview, TX 75602
903-758-5822 (office)
903-758-8155 (fax)

12501 W. County Road 122
Odessa, TX 79765
432-563-5400 (office)
855-291-0932 (fax)

15995 N. Barkers Landing
Suite 120
Houston, TX 77079
281-670-6665 (office)
770-308-7210 (fax)

International Locations

ARGENTINA

Parque Industrial Neuquen MZA R
Neuquen, Argentina Q8300AYU
855-252-5887 (office)

AUSTRALIA

South Australia
Unit 2A, 38 Cavan Road
Dry Creek, SA 5094
855-252-5887 (office)

CANADA

Alberta
116, 469 McCoy Drive
Red Deer, AB T4E 0A4
403-346-5550 (office)
403-346-5575 (fax)

#106, 6902 - 98th Street
Clairmont, AB T0H 0W0
780-830-1990 (office)
780-830-7997 (fax)

Saskatchewan

106 5th Street
Estevan, SK S4A 0Z4
306-634-4001 (office)
306-634-4204 (fax)

CHINA

No 7 Guanghua Road
Hanwei Plaza (West Wing) Room 11 B 5
Beijing, China 100004
855-252-5887 (office)

COLOMBIA

Parque Industrial Japón-Perú, Bodega 4.
Km 4.5 Vía Siberia - Funza
Cundinamarca
Colombia
855-252-5887 (office)

MEXICO

Ave. San Rafael Lote # 27B
Parque Moll Industrial
88756 Reynosa, TM
52-899-141-0866 (office)

Gaona #100
Col. Las Granjas
93327 Poza Rica, VER
52-899-141-0866 (satellite office)

OMAN

Block Number 252, Plot Number 1091
Way Nos: 5207
Opposite Home Centre Logistics
Ghala, Sultanate of Oman
855-252-5887 (office)

SAUDI ARABIA

Makkah Street, Endeskom Industrial Area
Dhahran 34521
Eastern Province
Kingdom of Saudi Arabia
855-252-5887 (office)

Table of Contents

Milling and Cleanout Services

- Titan Motor
- F5[®] Downhole Motor
- All Metal Motor
- Carbide Mill
- TTS PDC Bits
- Roller Cone Bit
- 2-Bladed Underreamer
- Wash Pipe and Shoes

Abrasive Cutting and Perforating Technology

- Abrasive Release Connector
- NitroTuff[®] Abrasive Perforator
- NitroTuff[®] Abrasive Cutter
- Slotting Tool
- Perforating Sleeve Sub

Premium Downhole Equipment

- M-50 Packer
- HydraSet[®] CT Jar
- HZ Fishing Jar
- Accelerator
- XR[®]
- WavForce[™] XR[®]
- Vibration Isolation Tool
- Motor Isolation Tool
- Hydraulic Setting Tool
- Venturi Junk Basket
- Circulating Junk Basket
- Gauge Carrier
- Phase Separator
- HydraSweep[®]
- Trip-N-Tool (TNT[®])
- DynaPulse

Table of Contents Continued

Coiled Tubing Conveyed Support Tools

- External Slip Type Coiled Tubing Connector
- Slim Line Coiled Tubing Connector
- Dimple Coiled Tubing Connector
- Hydraulic Installation Tool
- Anti-Rotation Roll-On Connector
- Stabilized Back Pressure Valve
- Back Pressure Float Valve
- Hydraulic Disconnect
- Motor Head Assembly
- Circulating Sub
- Bend Sub
- Magnet Sleeve Sub
- Lockable Swivel
- Safety Union
- Torque-Thru Sealed Knuckle Joint
- Nipple Locator
- Bow Spring Centralizer
- Weight Bar
- Boot Basket

Fishing Services

- Overshot
- Continuous Tubing Overshot
- Cutting Overshot
- Overshot Pack-Off Sub
- HydraVac
- GS Spear
- JDC Overshot
- Pump-Thru Wire Grab
- Pump-Thru Rope Spear
- Deployment Bar

Table of Contents Continued

Snubbing and Tubing Accessory Equipment

- Pump-Off Check Valve
- Pump-Off Bit Sub
- Safety Joints
- Sliding Sleeve Bit Sub
- Snubbing Back Pressure Valve
- Relief Valve
- Profile Nipple
- Pump-Thru Lock

Wash Tool Accessories

- Roll-On Connector
- Back Pressure Valve
- Sealed Knuckle Joint
- Wash Nozzle
- Pump-Off Wash Nozzle
- Spinning Wash Tool

E-Coil Equipment

- Surface Bulkhead
- Cablehead

Frac Diversion Technology

- SlicFrac®

Torque Measurement Devices

- E-Wrench®
- E-Vise™

Chemicals

BHA Pages

- Milling Assembly
- Bypassing Perforating System

TITAN MOTOR

The high performance Titan Motor was designed exclusively for the workover/coiled tubing market. It provides many hours of reliable service under demanding operating conditions, such as repeated jarring and side loading from working in horizontal wells.

The sealed bearing pack incorporates a patented bearing section that has no traditional roller or ball bearings, which can become damaged when jarred upon. It utilizes a set of self lubricated sleeve and washer bearings that operate in a sealed "oil bath". This motor design has proven itself with several years of very dependable and economical service.

FEATURES

- » Thrust Washer Bearings
- » Mud Lube or Sealed Bearing Pack
- » Hot Hole and N₂ Applications
- » Ability to Withstand Jar Impact
- » Robust Side Loading Strength

All motors are specially "fit" for every job to ensure the best results for any given scenario. Contact a Thru Tubing Solutions representative to discuss your specific needs.



TITAN MOTOR

SPECIFICATIONS

O.D.	FLOW RANGE	CONNECTION
in.	bpm	
mm	Lpm	
1.70	0.5 - 1.2	1" AM MT
43.2	80 - 191	
2.13	0.5 - 1.4	1-1/2" AM MT
54.0	80 - 223	
2.88	0.5 - 3.5	2-3/8" PAC
73.0	80 - 557	

F5 DOWNHOLE MOTOR

The F5 Motor is a heavy duty motor that is built for extreme durability and maximum torque. It includes a rugged bearing section that has been engineered to outlast the more challenging drilling operations and aggressive environments. The power section is capable of producing tremendous torque without a significant increase in pressure, and can handle higher flow rates when compared to conventional motors in the industry.

FEATURES

- » High Flow Rates - Higher Annular Velocity
- » High Torque Ratings To Reduce Stalls
- » Rotor Catch Feature
- » Sealed Bearing Assembly
- » Robust Design Optimized for Deviated Wellbores

All motors are specially “fit” for every job to ensure the best results for any given scenario. Contact a Thru Tubing Solutions representative to discuss your specific needs.



F5 DOWNHOLE MOTOR

SPECIFICATIONS

O.D.	FLOW RANGE	CONNECTION
in.	bpm	
mm	Lpm	
3.13	1.0 - 5.0	2-7/8" PAC
79.4	159 - 795	

ALL METAL MOTOR

The metal motor combines a standard motor bearing pack with a power section that uses both a metal rotor and a metal stator. Typical stators use an internal rubber core bonded to a steel housing which can be susceptible to swelling or debonding in certain chemical environments downhole. Unlike rubber stators, a metal stator will have both a high chemical resistance and a broad temperature range to make it one of the most versatile motors on the market.

FEATURES

- » Durable Design
- » Resistant to many chemicals
- » No temperature limitations

All motors are specially “fit” for every job to ensure the best results for any given scenario. Contact a Thru Tubing Solutions representative to discuss your specific needs.



ALL METAL MOTOR

SPECIFICATIONS

O.D.	FLOW RANGE	CONNECTION
in.	bpm	
mm	Lpm	
1.69	0.75 - 1.5	1" AM MT
42.9	119 - 238	
2.13	1.0 - 2.3	1-1/2" AM MT
54.0	159 - 366	
2.88	1.5 - 3.5	2-3/8" PAC
73.0	238 - 556	
3.13	2.4 - 4.0	2-7/8" PAC x
79.4	382 - 636	2-3/8" REG

CARBIDE MILL

The Carbide Mill has become the standard for normal cleanouts. This economical mill can have any combination of shapes and sizes to meet customer needs.

Mill designs can be comprised of several features including:

- » Standard and reverse clutch
- » Flat, convex or concave bottom
- » Tapered, step, string or watermelon profiles
- » Crushed carbide, Star Cut carbide or carbide inserts
- » Straight or Twister mill bodies

FEATURES

- » Custom Sizing
- » Cement Removal
- » Cast Iron Bridge Plug Removal
- » Composite Plug Removal
- » Scale Drilling
- » Open Hole Drilling

We recommend contacting a Thru Tubing Solutions representative for determining the proper mill for a given situation.



TTS PDC BITS

Thru Tubing Solutions' PDC Bits are designed to reduce motor stalls and keep the cuttings small. The cutting structure is designed to create a stable drilling environment which helps protect the PDC cutting elements thereby extending the life of the drill bit for longer laterals with a higher number of plugs.

FEATURES

- » Tougher Cutting Structure
- » Utilizes Premium PDC Cutters
- » Increased Wear Resistance of Gage Pads

We recommend contacting a Thru Tubing Solutions representative for determining the proper bit for a given situation.



TTS PDC BITS

SPECIFICATIONS

O.D.		LENGTH	CONNECTION
in.	ft.		
mm	m		
3.50	0.93		2-3/8" PAC
88.9	0.28		
3.63	0.92		2-3/8" PAC
92.2	0.28		
3.75	0.93		2-3/8" PAC
95.3	0.28		
3.88	0.93		2-3/8" PAC
98.4	0.28		
4.38	0.99		2-3/8" REG
111.2	0.30		
4.50	1.00		2-3/8" REG
114.3	0.30		
4.63	1.01		2-3/8" REG
117.5	0.31		

ROLLER CONE BITS

Thru Tubing Solutions can provide roller cone style bits as well as a complete line of diamond bits through it's third-party vendors.

FEATURES

- » Standard Connections
- » Wide Size Range
- » Natural and PDC Diamond



We recommend contacting a Thru Tubing Solutions representative for determining the proper bit for a given situation.

2-BLADED UNDERREAMER

The 2-Bladed Underreamer is used to drill obstructions such as cement, sand, scale and bridge plugs below a restriction. This tool is designed to work with a motor or threaded tubing. The Underreamer blades are actuated by pump pressure forcing a piston to expand the blades into their operating position. The blades are continuously cleaned as fluid flows through the tool. Once the pump is shut off, the blades can retract back into the body. This design utilizes a fully contained pivot pin that secures the blades with greater reliability than other designs.

FEATURES

- » Unique Custom Blade Design
- » Interchangeable Mill
- » Blade Cleaning Flow

We recommend contacting a Thru Tubing Solutions representative for determining the exact tool for a given situation.

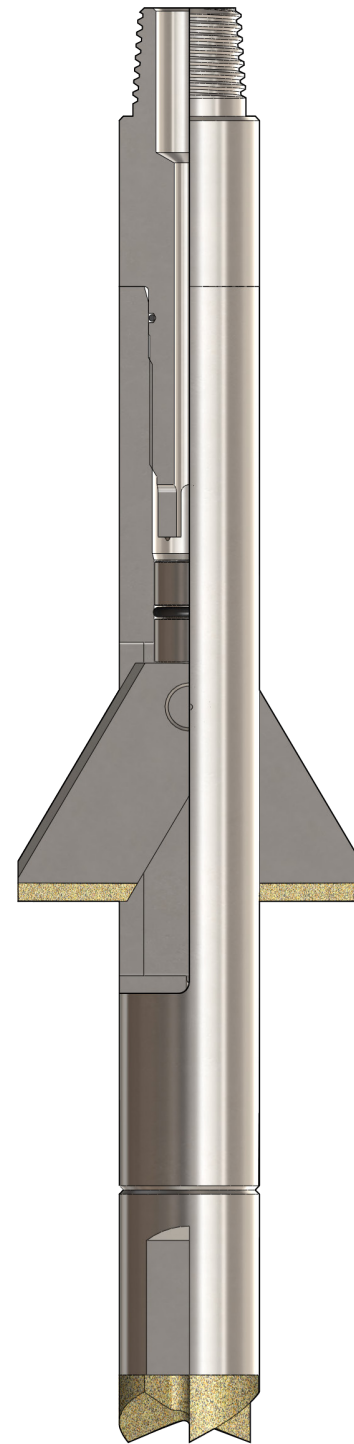

2-BLADED UNDERREAMER

SPECIFICATIONS

O.D.	LENGTH	OVERPULL	TORQUE	*MAX SPAN	CONNECTION
in. mm	ft. m	lbs. kg	ft-lbs Nm	in. mm	
1.70 43.2	1.35 0.41	50,000 22,680	460 624	4.51 114.7	1" AM MT
2.13 54.0	1.78 0.54	70,630 32,037	994 1,348	6.13 155.5	1-1/2" AM MT
2.88 73.0	2.25 0.69	129,500 58,740	1,937 2,626	7.00 177.8	2-3/8" PAC
3.13 79.4	2.12 0.65	117,329 53,220	3,035 4,115	8.25 209.5	2-3/8" REG

* Max blade spans shown are limited to maintaining tool O.D. Other sizes are available upon request.

WASH PIPE & SHOES

The carbide dressed shoes are used to wash over obstructions including bridge plugs, packers, locks (prongs), coiled tubing, wireline tool strings, coiled tubing tool strings, etc. Shoes are available in many different designs, however, wash pipe may be necessary for longer obstructions. We recommend contacting a fishing tool supervisor to accommodate your exact shoe and wash pipe requirements.

FEATURES

- » Custom Sizes Available
- » High Tensile Alloys Available



ABRASIVE RELEASE CONNECTOR

The Abrasive Release Connector combines the functionality of a coiled tubing connector and a disconnect into one tool. This combination allows for a shorter BHA as well as the ability to leave the entire BHA disconnected downhole. If the BHA were to become stuck, a ball is dropped from surface to activate the tool. Once landed, this ball redirects flow to a cutting mechanism within the Abrasive Release Connector. After redirecting the flow, an abrasive slurry is pumped from surface and within a matter of minutes, the abrasive slurry cuts the tool, separating the BHA from the coiled tubing. What is left is a 'slick' OD that matches the coiled tubing with no external upsets to catch on additional debris while pulling out of hole, reducing the likelihood of having to cut coil at surface.

FEATURES

- » Provides a shorter BHA by combining two tools into one
- » Replaces standard hydraulic disconnect
- » Leaves a 'slick string' OD equal to the coiled tubing

We recommend contacting a Thru Tubing Solutions representative for determining the exact tool for a given situation.



ABRASIVE RELEASE CONNECTOR

SPECIFICATIONS

COIL O.D.	O.D.	I.D.	LENGTH	CONNECTION
NOM	in. mm	in. mm	ft. m	
2.38	2.88 73.2	1.00 25.4	1.01 0.30	2-3/8" PAC
2.38	3.13 79.2	1.00 25.4	1.02 0.31	2-7/8" PAC
2.63	2.88 73.2	1.00 25.4	1.02 0.31	2-3/8" PAC
2.63	3.13 79.2	1.00 25.4	1.02 0.31	2-7/8" PAC

* Tools available to accommodate most common wall thicknesses

NITRO TUFF ABRASIVE PERFORATOR

The High Velocity Abrasive Perforating Tool has special port design and positioning for directing an abrasive fluid through tubing or casing into the formation. Running this tool with a special mixture of abrasive fluids accomplishes a complete perforation of the well. Because of the design of the Abrasive Perforating System, multiple perforations are possible on a single trip in the hole. Case histories have shown over 200 perforations on a single trip. Custom tool designs are available to provide the desired perforations per foot.

Not only is this system a viable alternative to TCP or conventional wireline perforating, but it can also perforate wells where other systems are not an option. The system has proven successful in perforating drill collars, drill pipe, and multiple casing strings in a single trip.

FEATURES

- » Multiple Zone Perforations in One Trip
- » Heavy Wall and Multi-String Perforations
- » Horizontal Well Applications
- » Custom Sizes Available
- » Nitro-Tuff Perforators Available in all Configurations

PERFORATOR TYPES

- » Planar Perforator
- » Spiral Perforator
- » Slim-Hole Perforator
- » Oriented Perforator
- » Bypassing Perforator

We recommend contacting a Thru Tubing Solutions representative to determine the exact configuration for a given situation.

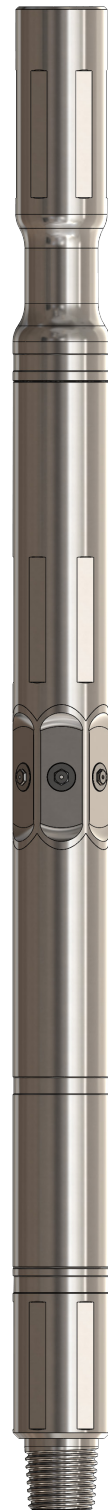

NITRO TUFF BYPASSING PERFORATOR

SPECIFICATIONS

O.D.	I.D.	LENGTH	OVERPULL	TORQUE	DROP BALL	CONNECTION
in. mm	in. mm	ft. m	lbs. kg	ft-lbs Nm		
2.88 73.0	0.50 12.7	3.07 0.94	174,856 79,313	4,489 6,086	0.562" / 0.625"	2-3/8" PAC
3.25 83.0	0.53 13.5	3.54 1.08	99,200 44,996	2,500 3,390	0.562" / 0.625"	2-3/8" PAC
3.50 88.9	0.53 13.5	3.55 1.08	99,200 44,996	2,500 3,390	0.562" / 0.625"	2-3/8" PAC

NITRO TUFF ABRASIVE CUTTER

The High Velocity Abrasive Cutting Tool has special port positioning for directing an abrasive fluid jet stream into the ID of the pipe to be severed. Running this tool with the Titan down hole motor and a special mixture of abrasive fluids accomplishes a complete severing of the tubular. As this tool rotates below the motor, the abrasive fluids penetrate and sever the tube where the jet stream makes contact. The result is a clean cut without any flaring of the tubular.

FEATURES

- » Ability to Cut Tubing, Casing, Completion Components, Drill Pipe & Drill Collars
- » Horizontal Well Applications
- » Clean Cut, No Flared Ends After Cut
- » Custom Sizes Available

We recommend contacting a Thru Tubing Solutions representative to determine the exact tool for a given situation.



SLOTTING TOOL

The Slotting Tool is to be used in conjunction with any of the TTS abrasive perforators. This tool allows the abrasive perforator to move down-hole several inches during the perforating process to create slots in the casing. By reducing the pump rate the Slotting Tool can be reset allowing for additional openings to be created. These large channels provide increased communication to the formation while still maintaining casing integrity.

FEATURES

- » Adjustable Cutting Speed
- » Customized Slot Lengths
- » Easily Reset for Subsequent Slots
- » Unlimited Slots in a Single Run

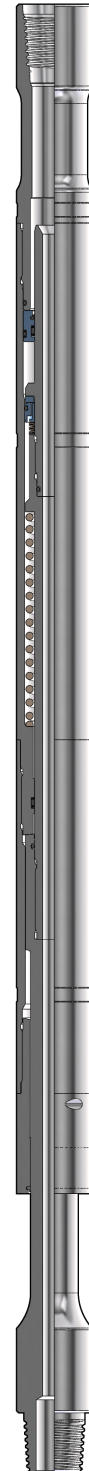

SLOTTING TOOL

SPECIFICATIONS

O.D.	I.D.	LENGTH	OVERPULL	TORQUE	CONNECTION
in.	in.	ft.	lbs.	ft-lbs	
mm	mm	m	kg	Nm	
2.88	0.88	4.46	123,619	4,489	2-3/8" PAC
73.2	22.4	1.36	56,073	621	

PERFORATING SLEEVE SUB

For single-trip operations requiring a delayed activation of an Abrasive Perforating Tool, the Perforating Sleeve Sub can be used. A ball can be dropped from surface, to shift open a sleeve that exposes the jet nozzles and begin the abrasive perforating process. After the ball is dropped from surface to shift the internal sleeve, all of the tools below the Perforating Sleeve Sub are isolated for the remainder of the job. This tool can be customized for various jet nozzle configurations and initiation pressures.

FEATURES

- » Ball-Drop Activated
- » Flow thru ID until Ball Lands
- » Custom Jet Nozzle Profiles Available

We recommend contacting a Thru Tubing Solutions representative to determine the exact tool for a given situation.



M-50 PACKER

The M-50 Packer was engineered to withstand sand debris associated with abrasive perforating and fracing numerous zones within a wellbore. Large flow-thru ports prevent sand build up on moving parts to ensure reliable operation downhole.

FEATURES

- » J-Slot Compression Set for Repeated Operation
- » Optimized for Use with Perforating and Fracing
- » Equalizing Safety Valve



M-50 PACKER

SPECIFICATIONS

CASING SIZE		CASING WEIGHT	O.D.	LENGTH	OVERPULL
in.	mm	lbs kg/m	in. mm	ft. m	lbs kg
4-1/2	114.3	15.1 22.47	3.73 94.7	5.77 1.76	89,657 40,667
4-1/2	114.3	9.5 - 13.5 14.14 - 20.09	3.85 97.8	5.81 1.77	89,657 40,667
5	127.0	18 26.79	4.06 103.1	5.77 1.76	89,657 40,667
5-1/2	139.7	20 - 23 29.76 - 34.23	4.50 114.3	5.75 1.75	72,864 33,050
5-1/2	139.7	15.5 - 20 23.07 - 29.76	4.63 117.6	5.75 1.75	72,864 33,050
5-1/2	139.7	13 - 15.5 19.35 - 23.07	4.78 121.4	5.75 1.75	72,864 33,505

HYDRASET CT JAR

The TTS HydraSet Jar can be equipped with a hydraulic chamber which provides operators the ability to reset the jar hydraulically by increasing the differential pressure within the tool. Additional hydraulic chambers can be added to the assembly to adjust the differential pressure required to reset the jar for subsequent impacts. Each successive setting and firing of the jar can be performed without ever cycling coiled tubing, therefore extending coiled tubing string life and reducing cycle costs.

FEATURES

- » Engineered for Horizontal Applications
- » Low Reset Force Requirement
- » Hydraulic Reset Option/Assist
- » High Impact Ratio
- » Rugged, Compact Design
- » Permits Circulation During Operation



HYDRASET CT JAR

SPECIFICATIONS

O.D.	I.D.	RETRACTED LENGTH	EXTENDED LENGTH	OVERPULL	TORQUE	CONNECTION
in.	in.	ft.	ft.	lbs.	ft-lbs	
mm	mm	m	m	kg	Nm	
2.88	0.88	5.26	5.97	36,000	2,465	2-3/8" PAC
73.0	22.4	1.60	1.82	16,329	3,342	
3.13	0.88	5.26	5.97	43,000	5,879	2-7/8" PAC
79.2	22.4	1.60	1.82	19,505	7,971	

HZ FISHING JAR

The HZ Fishing Jar can be fired up or down multiple times simply by pushing or pulling on the immobilized tool string. A very low re-cocking force makes this design ideal for horizontal wells where pushing capabilities are limited. The jarring impact can easily be controlled by varying the applied force. No pre-setting or adjustments are needed before tripping in the hole or prior to jarring. A large thru bore is incorporated allowing ball actuated tools to be run below the jar.

FEATURES

- » Low Re-Cocking Force
- » Engineered for Horizontal Applications
- » Neutral Position
- » High Impact



HZ FISHING JAR

SPECIFICATIONS

O.D.	I.D.	RETRACTED LENGTH	EXTENDED LENGTH	OVERPULL	TORQUE	CONNECTION
in.	in.	ft.	ft.	lbs.	ft-lbs	
mm	mm	m	m	kg	Nm	
1.70	0.56	5.14	6.09	10,000	460	1" AM MT
43.2	14.2	1.57	1.86	4,536	624	
2.13	0.69	5.15	6.07	18,000	994	1-1/2" AM MT
54.0	17.5	1.57	1.85	8,165	1,348	
2.88	0.88	9.05	10.49	36,000	2,465	2-3/8" PAC
73.2	22.4	2.76	3.19	16,329	3,342	

ACCELERATOR

The Accelerator is a downhole tool used with a jar to increase the impact force as the jar is fired. The Accelerator uses a mechanical spring to store the energy released during operation, and it is typically recommended for shallow operations when the coiled tubing length does not provide sufficient potential energy to the impact.

FEATURES

- » Amplifies Jarring Impact
- » Flow-Thru Design with same ID as Jar
- » Torque-Thru



ACCELERATOR

SPECIFICATIONS

O.D.	I.D.	LENGTH	OVERPULL	TORQUE	CONNECTION
in.	in.	ft.	lbs.	ft-lbs	
mm	mm	m	kg	Nm	
1.70	0.56	2.93	41,900	355	1" AM MT
43.2	14.2	0.89	19,006	481	
2.13	0.69	3.97	73,041	628	1-1/2" AM MT
54.0	17.5	1.21	33,131	851	
2.88	0.88	4.93	159,865	4,489	2-3/8" PAC
73.0	22.4	1.50	72,514	6,086	
3.13	0.88	5.28	195,742	5,879	2-7/8" PAC
79.2	22.4	1.61	88,787	7,971	

XRV

Thru Tubing Solutions' XRV is a dynamic excitation tool that enables coiled tubing to reach depths that were previously unobtainable. Engineered without moving parts or elastomers, this tool can handle virtually any environment, chemical or temperature. The innovative, compact design utilizes a specialized flow path to create a varying flow resistance which acts much like an opening and closing valve. It is the shortest, most reliable extended reach tool on the market.

FEATURES

- » Compact, Rugged Design
- » No Moving Parts – Highly Reliable
- » Unlimited Temperature Range
- » No Elastomers – Compatible with any Fluid
- » Wide Range of Operational Flow Rates
- » Low Differential Pressure



XRV

SPECIFICATIONS

O.D.	LENGTH	OVERPULL	TORQUE	FLOW RATE	CONNECTION
in.	ft.	lbs.	ft-lbs	bpm	
mm	m	kg	Nm		
1.25	1.10	22,081	327	0.5	7/8" AM MT
31.8	0.34	10,016	443		
1.69	1.20	42,943	460	1	1" AM MT
42.9	0.37	19,479	624		
2.13	1.39	61,302	994	1.5, 2, or 2.5	1-1/2" AM MT
54.0	0.42	27,806	1,348		
2.88	2.24	162,166	4,489	2.5, 3, 3.5, 4, or 4.5	2-3/8" PAC
73.0	0.58	73,557	6,086		
3.13	2.54	190,716	5,879	2.5, 3, 3.5, 4, or 4.5	2-7/8" PAC
79.2	0.77	86,507	7,971		

WAVFORCE XRV

The WavForceXRV represents the most cutting-edge extended reach technology on the market. This completely redesigned tool is tuned for maximum coiled tubing vibration while maintaining low operating pressures. Engineered with an open flow path, the WavForceXRV never fully blocks all flow through the tool, ensuring circulation capability. Combined with Thru Tubing Solutions' proven BHA, this tool provides maximum run in speeds for shortest time on location.

FEATURES

- » Low operating pressures
- » Tool action tuned for maximum tubing vibration
- » Ball drop option allows for maximum vibration when needed



WAVFORCE XRV

SPECIFICATIONS

O.D.	LENGTH	OVERPULL	FLOW RATE	CONNECTION
in. mm	ft. m	lbs. kg	bpm	
2.88	3.83	115,500	3 - 4	2-3/8" PAC
73.1	1.17	52,390		
3.13	3.99	105,183	4 - 5	2-3/8" REG
79.2	1.22	47,710		

VIBRATION ISOLATION TOOL

The Vibration Isolation Tool (VIT) was designed for use when TCP guns are run with an XRV tool. The VIT protects TCP guns from vibrations produced by pressure pulses that are created when using a vibratory tool. It is designed with a mechanical dampening feature that was engineered to be in tune with the XRV frequency.

The VIT provides a safe means for running TCP guns in long laterals where it is necessary to use an extended reach tool.

FEATURES

- » Protects TCP Guns from Vibratory Tools
- » Specifically Tuned for XRV



VIBRATION ISOLATION TOOL

SPECIFICATIONS

O.D.	I.D.	LENGTH	OVERPULL	TORQUE	CONNECTION
in.	in.	ft.	lbs.	ft-lbs	
mm	mm	m	kg	Nm	
2.88	0.88	4.93	174,856	4,489	2-3/8" PAC
73.2	22.4	1.50	79,313	6,086	

MOTOR ISOLATION TOOL

The Motor Isolation Tool is intended for use when a TTS downhole motor is used in conjunction with the XRV to operate in extended length horizontal wells. The Motor Isolation Tool is placed between the motor and the XRV to provide protection to the motor from the vibrational output of the XRV. It contains a mechanical dampening feature that is specifically configured to the vibrational frequency produced by the XRV.

FEATURES

- » Protects Motor from Vibrational Output
- » Specifically Configured to XRV frequency
- » Reduces potential impact damage to bit

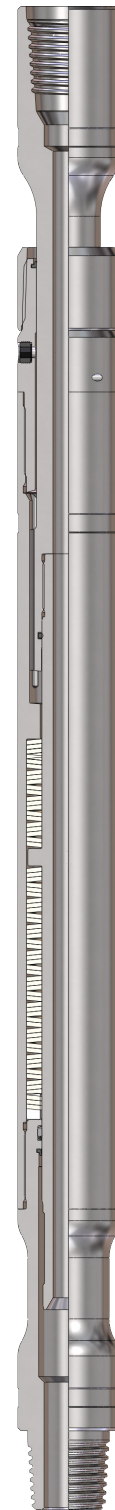

MOTOR ISOLATION TOOL

SPECIFICATIONS

O.D.	I.D.	LENGTH	OVERPULL	TORQUE	CONNECTION
in.	in.	ft.	lbs.	ft-lbs	
mm	mm	m	kg	Nm	
2.88	0.88	3.41	162,101	3,001	2-3/8" PAC
73.2	22.4	1.04	73,528	4,069	

HYDRAULIC SETTING TOOL

Thru Tubing Solutions' Hydraulic Setting Tool is the shortest on the market making it ideal for horizontal applications. The unique flow-thru feature allows for washing away any sediment or debris that could prevent a plug from sealing or engaging properly.

FEATURES

- » Short Tool Length
- » Compatible with Standard Plugs
- » Flow Thru Capabilities
- » Can be Run with Perforators

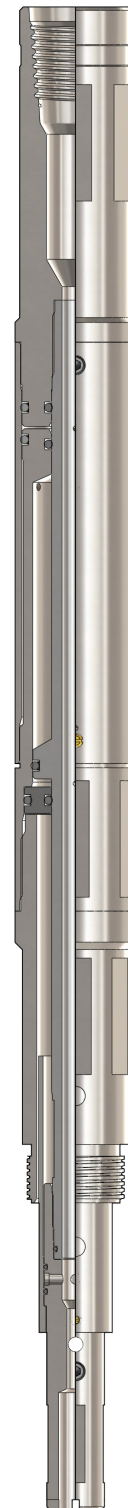

HYDRAULIC SETTING TOOL

SPECIFICATIONS

	O.D.	I.D.	LENGTH	OVERPULL	TORQUE	CONNECTION
NOM	in. mm	in. mm	ft. m	lbs. kg	ft-lbs Nm	
1-11/16 Go	1.81 45.9	0.31 7.9	3.63 1.12	19,880 9,017	N/A	1" AM MT
#5	1.81 45.9	0.31 7.9	3.32 1.01	19,745 8,956	460 624	1" AM MT
#10	3.13 79.5	0.44 11.2	2.44 0.74	49,000 22,226	350 475	2-3/8" PAC
#20	3.81 96.7	0.44 11.2	2.50 0.76	92,600 42,003	1,025 1,390	2-3/8" PAC

VENTURI JUNK BASKET

The Venturi Junk Basket works by pumping fluid or nitrogen down the coiled tubing creating a venturi action. This causes suction at the bottom of the tool pulling debris into the basket where it is trapped. Finger grabs hold the debris until it can be removed from the well bore. The Venturi Basket may also be run with a motor.

FEATURES

- » Removes Loose Debris
- » Various Extension Lengths
- » Milling Option Available

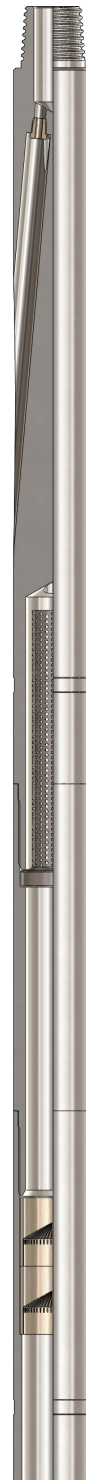

VENTURI JUNK BASKET

SPECIFICATIONS

O.D.	LENGTH	OVERPULL	TORQUE	CONNECTION
in.	ft.	lbs.	ft-lbs	
mm	m	kg	Nm	
1.70	3.84	50,000	460	1" AM MT
43.2	1.17	22,680	624	
2.13	4.39	57,610	1,487	1-1/2" AM MT
54.0	1.34	26,132	2,016	
2.88	4.32	106,202	3,674	2-3/8" PAC
73.0	1.31	48,172	4,981	

CIRCULATING JUNK BASKET

The Circulating Junk Basket features a sliding junk housing that can “scoop” up debris, as it is pushed into lateral sections. Once the tools reach bottom the string is quickly pulled up causing the housing to slide down and secure the debris inside.

FEATURES

- » Flow-Thru
- » Large Debris Chamber
- » Scooping Feature



CIRCULATING JUNK BASKET

SPECIFICATIONS

NOM	O.D.	LENGTH	OVERPULL	TORQUE	CONNECTION
	in. mm	ft. m	lbs. kg	ft-lbs Nm	
3.50	3.60	4.91	50,000	460	2-3/8" PAC
	91.4	1.50	22,680	624	
3.63	3.88	4.91	50,000	460	2-3/8" PAC
	98.6	1.50	22,680	624	
4.00	4.50	5.87	70,630	994	2-3/8" PAC
	114.3	1.79	32,037	1,348	
5.50	6.13	5.87	70,630	994	2-3/8" PAC
	155.7	1.79	32,037	1,348	

GAUGE CARRIER

The Gauge Carrier provides a means for housing two gauges on the BHA and providing the required protection to ensure accurate downhole data readings throughout the course of the operation.

GAUGE OPTIONS

VIBRATORY GAUGE

- » Measures Accelerations
- » 1 Million Sample Capacity
- » Temperature -- Up to 350° F
- » Burst Data Collection

INCLINOMETER GAUGE

- » Measures Accelerations
- » 1 Million Sample Capacity
- » Temperature -- Up to 350° F
- » Burst Data Collection

PRESSURE/TEMPERATURE GAUGE

- » Downhole Pressure and Temperature Measurement
- » Max Pressure Reading -- 20,000 PSI
- » Max Temp -- Up to 350° F
- » 1 Million Data Sets of Memory

HIGH SPEED PRESSURE GAUGE

- » Downhole Pressure and Temperature Measurement
- » Max Pressure Reading -- 20,000 PSI
- » Max Temp -- Up to 350° F
- » 1 Million Data Sets of Memory
- » Burst Data Collection

All gauges use smart battery technology to ensure accurate performance of our tools while downhole. Once the battery is connected to the gauge, the gauge immediately starts to record data. With the help of the gauges, TTS is able to obtain performance of the tools, pressure changes, and temperature all at the same time. After the job is complete, all of the gauge data is downloaded via USB.



GAUGE CARRIER

SPECIFICATIONS

O.D.	I.D.	LENGTH	OVERPULL	TORQUE	CONNECTION
in.	in.	ft.	lbs.	ft-lbs	
mm	mm	m	kg	Nm	
2.88	1.25	2.98	127,365	4,489	2-3/8" PAC
73.2	31.8	0.90	57,772	6,086	
3.13	1.25	2.98	223,822	5,879	2-7/8" PAC
79.5	31.8	0.90	101,524	7,971	

PHASE SEPARATOR

The Phase Separator is used to separate gas out of comingled fluids prior to being pumped through downhole motors. These comingled fluids can cause motors to spin at extremely high RPMs while running in hole which can significantly reduce the life of the power section. This tool can easily be configured to divert the compressed gas to the annulus at various rates.

FEATURES

- » Protects the Down-Hole Motors from High RPMs
- » Can be Specifically Tuned for Various Rates
- » Made from Coated Materials to Prevent Erosion



PHASE SEPARATOR

SPECIFICATIONS

O.D.	LENGTH	OVERPULL	CONNECTION
in.	ft.	lbs.	
mm	m	kg	
1.70	1.15	50,000	1" AM MT
43.1	0.4	22,680	
2.13	1.51	70,630	1-1/2" AM MT
54.1	0.4	32,037	
2.88	1.98	173,505	2-3/8" PAC
73.2	0.6	78,701	
3.13	1.98	184,399	2-7/8" PAC
79.5	0.6	83,642	

HYDRA-SWEEP

The HydraSweep is a multi-cycle circulating valve that allows operators to divert flow to the annulus and back through the tool string as often as necessary by manipulating the fluid flow to the tool. The design allows for unlimited sequencing without the need to circulate any balls down the coiled tubing.

Pump pressure can be used as an indicator of circulation valve position. For example, a pressure decrease will be seen when flow is diverted to the annulus.

FEATURES

- » Unlimited Cycles
- » Increased Annular Velocity
- » Coiled Tubing Applications
- » Acid Compatibility
- » No Balls to Drop
- » Immediate Flow Diversion on Demand Saves Fluid
- » Options for 100% Flow Diversion or Limited Flow to Motor



HYDRA-SWEEP

SPECIFICATIONS

O.D.	I.D.	LENGTH	OVERPULL	TORQUE	CONNECTION
in.	in.	ft.	lbs.	ft-lbs	
mm	mm	m	kg	Nm	
2.13	0.75	7.57	70,630	994	1-1/2" AM MT
54.0	19.1	2.31	32,037	1,348	
2.88	0.85	8.00	174,856	4,489	2-3/8" PAC
73.2	21.6	2.44	79,313	6,086	
3.13	1.13	8.23	223,822	5,879	2-7/8" PAC
79.5	28.7	2.51	101,524	7,971	

TRIP-N-TOOL (TNT)

The TNT was designed to reduce the overall cost and eliminate the need for multiple trips; thus putting the well onto production sooner. Split string milling allows the customer to run the entire length of production tubing at one time, with less work string required; reducing their overall rental charges and trip time. Providing a dual barrier within the TNT eliminates the need for a snubbing unit and slick line operations, while ensuring the job is completed safely.

Once all plugs have been milled out and TD reached, a ball is pumped to shift an internal seat, which releases the lower portion of the TNT. The motor/bit are pumped off and left downhole, below the bottom perforations; simultaneously this closes dual flapper valves to maintain well control. Tubing is then tripped out of hole, until the desired production depth is reached. Once tubing is landed and the wellhead secured, a dissolvable ball is dropped to permanently open the dual flapper valves, leaving the tubing string ready for production. This innovative design eliminates additional surface equipment and flow back operations.

FEATURES

- » Single Trip to Mill and Hang Production String
- » Compatible with Motor or Rotary Drilling
- » Maintain Well Control with Dual Flappers
- » Short Design
- » No Flow Back of Internals Required



TRIP-N-TOOL (TNT)

SPECIFICATIONS

O.D.	I.D. BEFORE PUMP-OFF	I.D. AFTER PUMP-OFF	LENGTH	OVERPULL	TORQUE	CONNECTION
in.	in.	in.	ft.	lbs.	ft-lbs	
mm	mm	mm	m	kg	Nm	
3.75	0.81	1.69	5.36	114,769	2,380	2-7/8" PAC
95.3	20.6	42.9	1.63	52,058	3,227	
3.88	0.81	1.86	5.39	159,456	3,050	2-7/8" PAC
98.4	20.6	47.2	1.64	72,328	4,135	

DYNA-PULSE

The DynaPulse wash tool was engineered with a unique fluid path to create a varying flow resistance; which acts much like an opening and closing valve. This action creates a strong, intense fluid pulsation through the tool for cleanout operations to remove residue such as scale, paraffin, sands, and other debris from the wellbore. Additionally, the pulsating action of the DynaPulse breaks static friction resulting in increased weight transfer that enables coiled tubing to reach TD in extended laterals.

The DynaPulse tool is extremely adaptable and can be used with any nozzle configuration for customized jetting to accommodate specific flow rates and pressure limitations.

FEATURES

- » No moving parts
- » No elastomers
- » Acid compatibility
- » Any wash nozzle configuration
- » Compatible with nitrogen and beads



DYNA-PULSE

SPECIFICATIONS

O.D.	LENGTH*	FLOW RATE	CONNECTION
in.	ft.	BPM	
mm	m		
1.25	1.30	.25 - 1.0	7/8" AM MT
95.5	1.57		
1.69	1.40	.50 - 1.5	1" AM MT
42.9	0.42		
2.13	1.70	.75 - 3.5	1-1/2" AM MT
54.1	0.52		
2.88	2.10	2.0 - 5.0	2-3/8" PAC
73.0	0.64		
3.13	2.50	2.0 - 5.5	2-7/8" PAC
79.2	0.76		

* Minimum length. Length will vary depending on wash nozzle configuration.

EXTERNAL SLIP TYPE CT CONNECTOR

The Coiled Tubing Connector is designed to allow a means of connecting a bottom hole assembly to the end of coiled tubing. This slip type connector is the ideal method for transfer of both tensile and torque from the coiled tubing to the bottom hole assembly.

FEATURES

- » Slip Type
- » Full I.D.
- » Torque Thru

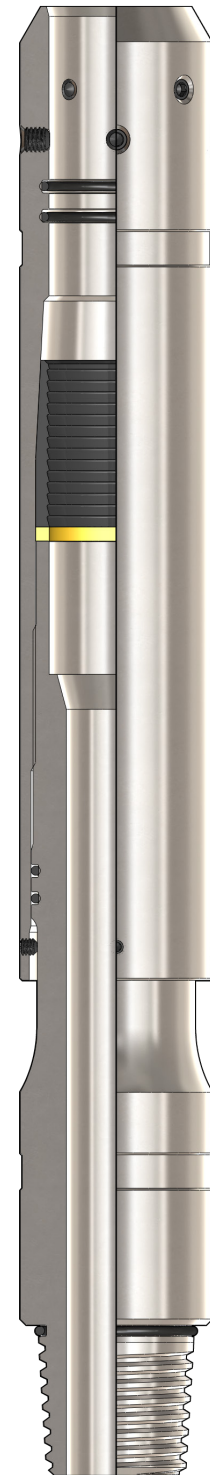

EXTERNAL SLIP TYPE CT CONNECTOR

SPECIFICATIONS

COIL O.D.	O.D.	I.D.	LENGTH	CONNECTION
NOM	in. mm	in. mm	ft. m	
1.00	1.70 43.2	0.69 17.5	1.02 0.31	1" AM MT
1.25	1.70 43.2	0.75 19.1	0.99 0.30	1" AM MT
1.25	2.13 54.0	1.00 25.4	1.27 0.39	1-1/2" AM MT
1.50	2.13 54.0	1.00 25.4	1.27 0.39	1-1/2" AM MT
1.50	2.88 73.0	1.13 28.7	1.49 0.45	2-3/8" PAC
1.50	3.06 77.7	1.38 35.1	1.68 0.51	2-3/8" 8 Rd Box
1.75	2.88 73.0	1.13 28.7	1.60 0.49	2-3/8" PAC
1.75	3.06 77.7	1.38 35.1	1.79 0.55	2-3/8" 8 Rd Box
2.00	2.88 73.0	1.38 35.1	1.64 0.50	2-3/8" PAC
2.00	3.06 77.7	1.69 42.9	1.83 0.56	2-3/8" 8 Rd Box
2.00	3.13 79.2	1.50 38.1	1.64 0.50	2-7/8" PAC
2.38	3.25 82.5	1.95 49.5	1.76 0.54	2-3/8" PAC
2.38	3.25 82.5	1.50 38.1	1.77 0.54	2-7/8" PAC
2.88	3.88 98.4	1.38 35.1	2.16 0.66	2-3/8" PAC

* Tools can be equipped with premium threads for a larger I.D.

SLIM LINE COILED TUBING CONNECTOR

The Slim Line CTC was designed for restricted wellbore applications. It incorporates the benefits of both an internal and external dimple type connector while maintaining a slim OD. Support on both the OD and the ID of the coiled tubing give it much greater holding strength than typical connectors. The Slim Line CTC is installed by utilizing the Hydraulic Installation Tool.

FEATURES

- » Provides Internal and External Support to Coiled Tubing
- » Stronger Than Typical Coiled Tubing Connectors
- » Slim OD

We recommend contacting a Thru Tubing Solutions representative for determining the exact tool for a given situation.



SLIM LINE COILED TUBING CONNECTOR

SPECIFICATIONS

COIL O.D.	O.D.	I.D.	LENGTH	CONNECTION
NOM	in. mm	in. mm	ft. m	
2.00	2.88 73.2	0.88 22.3	0.30 0.09	2-3/8" PAC
2.38	2.88 73.2	0.88 22.3	0.99 0.30	2-3/8" PAC
2.63	3.06 77.7	1.00 25.4	0.99 0.30	2-3/8" PAC
2.63	3.13 79.5	1.50 38.1	0.38 0.12	2-7/8" PAC
2.88	3.31 84.0	1.25 31.8	0.37 0.11	2-7/8" PAC
2.88	3.31 84.0	1.25 31.8	0.37 0.11	2-3/8" PAC

DIMPLE COILED TUBING CONNECTOR

The Dimple CT Connector is secured to the tubing by a series of set screws that seat in a pattern of impressions created with a specially designed dimpling tool. (See Hydraulic Installation Tool). This CT connector provides a relatively fast and easy way to secure the BHA to the coiled tubing while maintaining torque and tensile capabilities.

FEATURES

- » One Piece Design
- » Torque Thru
- » Simple Installation & Removal

Contact a TTS representative for Internal Dimple CT connector applications.



DIMPLE COILED TUBING CONNECTOR

SPECIFICATIONS

COIL O.D.	O.D.	I.D.	LENGTH	CONNECTION
NOM	in. mm	in. mm	ft. m	
1.50	1.88 47.8	0.75 19.1	0.52 0.16	1" AM MT
1.50	2.13 54.0	1.00 25.4	0.52 0.15	1-1/2" AM MT
1.75	2.13 54.0	1.00 25.4	0.48 0.15	1-1/2" AM MT
2.00	2.38 60.5	1.00 25.4	0.48 0.15	1-1/2" AM MT
1.50	2.88 73.0	1.38 35.1	0.61 0.19	2-3/8" PAC
1.75	2.88 73.0	1.38 35.1	0.58 0.18	2-3/8" PAC
2.00	2.88 73.0	1.38 35.1	0.54 0.16	2-3/8" PAC
2.38	3.00 76.2	1.38 35.1	0.54 0.16	2-3/8" PAC

HYDRAULIC INSTALLATION TOOL

The Hydraulic Installation Tool provides an efficient and consistent installation by utilizing hydraulic pressure to force dimpling pistons into the coiled tubing. This prevents uneven dimpling profiles and produces a more reliable connection between the coiled tubing and bottom-hole assembly. Installation time is also greatly reduced from standard, manual dimpling procedures.

FEATURES

- » Saves Time over Manual Dimpling Methods
- » Simple to Use
- » Creates a Consistent Dimple Profile
- » Designs Available for External, Internal and Slim Line Connectors

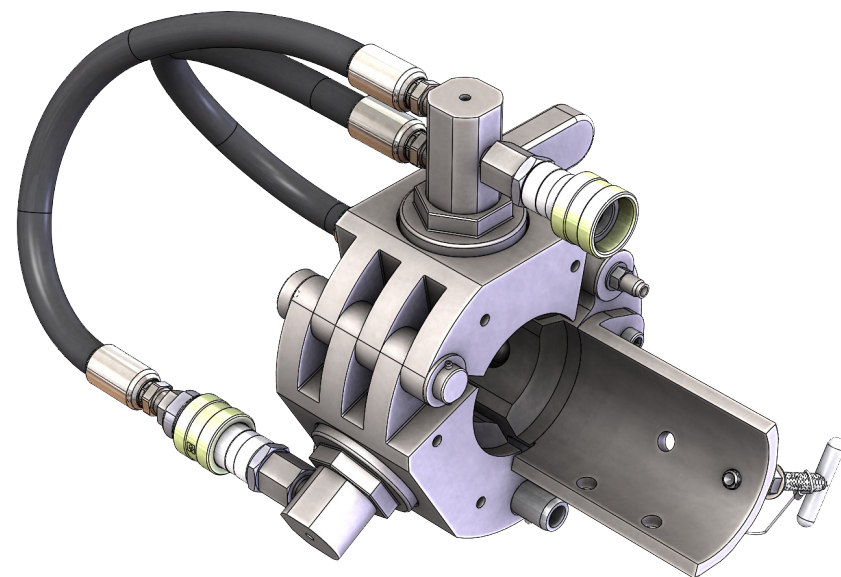

ANTI-ROTATION ROLL-ON CONNECTOR

The Anti-Rotation Roll-On Connector (AROC) is an improvement to standard roll-on connectors. The AROC provides superb torque thru capabilities while maintaining a slick OD and simple installation requirements.

FEATURES

- » Torque Thru
- » Slick OD



ANTI-ROTATION ROLL-ON CONNECTOR

SPECIFICATIONS

COIL O.D.	O.D.	I.D.	LENGTH	CONNECTION
NOM	in. mm	in. mm	ft. m	
1.25	1.25 31.8	0.63 15.9	0.40 0.12	7/8" AM MT
1.50	1.50 38.1	0.69 17.5	0.42 0.13	1" AM MT
1.50	1.94 49.3	0.69 17.5	0.46 0.14	1-1/2" AM MT
1.75	1.75 44.5	0.75 19.1	0.46 0.14	1" AM MT
1.75	1.94 49.3	0.75 19.1	0.46 0.14	1-1/2" AM MT
2.00	2.00 50.8	0.75 19.1	0.46 0.14	1" AM MT
2.00	2.00 50.8	0.75 19.1	0.46 0.14	1-1/2" AM MT
2.38	2.38 60.5	1.00 25.4	0.55 0.17	1-1/2" AM MT
2.38	2.88 73.2	1.38 35.1	0.54 0.16	2-3/8" PAC

STABILIZED BACK PRESSURE VALVE

The Stabilized Back Pressure Valve was developed for use in extreme conditions. Capable of handling higher flow rates for longer durations, the flapper is designed to stabilize (no valve flutter) when in the open position to reduce spring fatigue and component wear. The Stabilized Back Pressure Valve can be used in any application, but has been proven to out perform typical back pressure valves in high flow operations.

FEATURES

- » Stabilized flapper to prevent wear caused by flow-induced flapper motion
- » Single piece heavy duty body to prevent flapper/seal misalignment
- » Back up rings for higher pressure and better chemical resistance
- » Specific designs capable to being rated for 15k psi operating pressure

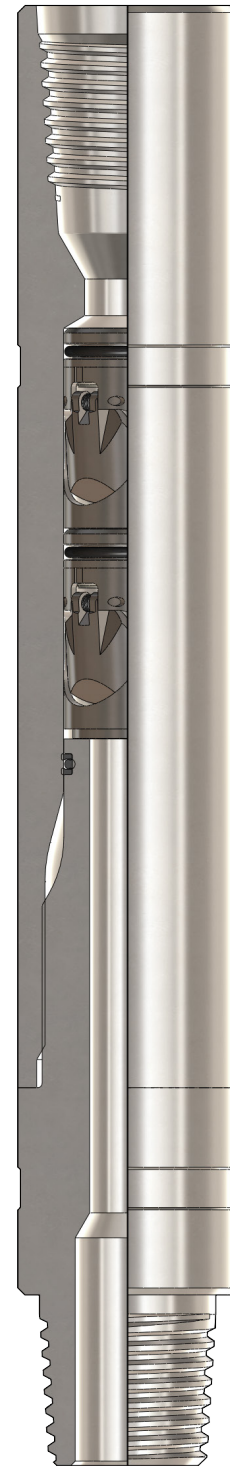

STABILIZED BACK PRESSURE VALVE

SPECIFICATIONS

O.D.	I.D.	LENGTH	OVERPULL	TORQUE	CONNECTION
in.	in.	ft.	lbs.	ft-lbs	
mm	mm	m	kg	Nm	
2.88	1.00	1.55	174,856	4,489	2-3/8" PAC
73.2	25.4	0.47	79,313	6,086	
2.91	1.00	1.75	108,218	2,473	2-3/8" PH6
73.9	25.4	0.53	49,087	3,353	
3.13	1.00	1.84	223,821	5,879	2-7/8" PAC
73.2	25.4	0.56	101,523	7,971	
3.44	1.00	1.75	198,400	4,400	2-7/8" PH6
87.4	25.4	0.53	89,993	5,966	
3.50	1.00	1.79	218,584	4,987	2-7/8" PH6
88.9	25.4	0.55	99,148	6,761	

BACK PRESSURE FLOAT VALVE

The Back Pressure Float Valve is primarily used with jointed pipe operations where continuous flushing, due to pipe manipulation, can stir up debris and prevent most types of valves from sealing properly. This tool is very tolerant of debris laden fluids and provides an additional safety barrier aside from typical valves included in the BHA.

FEATURES

- » Utilizes Industry Standard Plunger Valve Cartridge
- » Provides Metal-to-Metal and Elastomeric Seal
- » Debris Tolerant

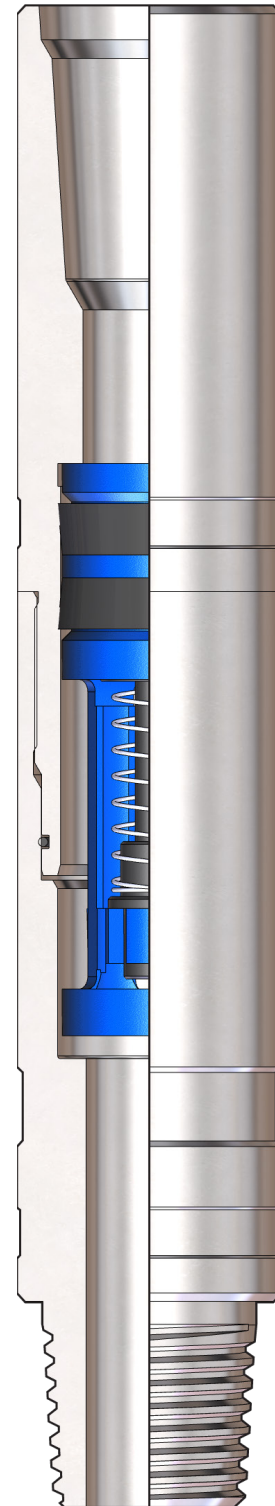

BACK PRESSURE FLOAT VALVE - BOX UP

SPECIFICATIONS

O.D.	LENGTH	OVERPULL	TORQUE	CONNECTION
in.	ft.	lbs.	ft-lbs	
mm	m	kg	Nm	
2.88	1.33	130,922	4,489	2-3/8" PAC
73.0	0.41	59,385	6,086	
3.13	1.10	223,822	5,879	2-7/8" PAC
79.5	0.33	101,524	7,971	

FLOAT VALVE BIT SUB - PIN UP

SPECIFICATIONS

O.D.	LENGTH	OVERPULL	TORQUE	CONNECTION
in.	ft.	lbs.	ft-lbs	
mm	m	kg	Nm	
3.06	1.10	174,856	4,489	2-3/8" PAC
77.2	0.34	79,313	6,086	

HYDRAULIC DISCONNECT

The Hydraulic Disconnect is an essential piece of equipment used for releasing the coiled tubing from the bottom hole assembly if it has become stuck while in the wellbore. Features include “hidden” internal shear screws that are fully retained and cannot come loose. This design transmits torque by use of internal splines that are far more durable than standard external “castles” which are more susceptible to damage.

FEATURES

- » Transmits Torque
- » Standard G.S. Type Internal Fishing Profile
- » Impact Resistant to Jarring

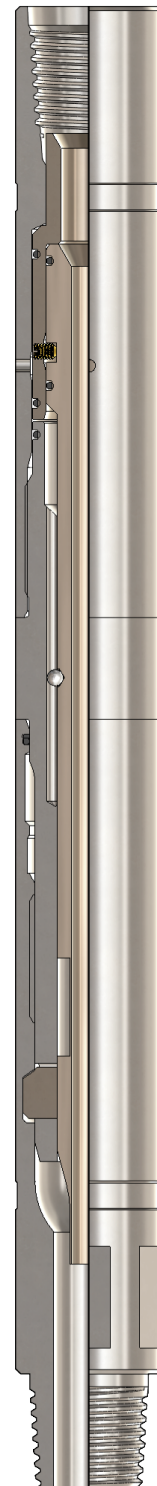

HYDRAULIC DISCONNECT

SPECIFICATIONS

O.D.	I.D.	LENGTH	OVERPULL	TORQUE	CONNECTION
in.	in.	ft.	lbs.	ft-lbs	
mm	mm	m	kg	Nm	
1.70	0.45	1.43	43,000	625	1" AM MT
43.2	11.5	0.44	19,505	847	
2.13	0.53	1.74	60,000	994	1-1/2" AM MT
54.1	13.5	0.53	27,216	1,348	
2.88	0.69	2.24	103,104	4,489	2-3/8" PAC
73.0	17.5	0.68	46,767	6,086	
3.13	0.81	2.70	135,720	5,879	2-7/8" PAC
79.5	20.6	0.82	61,562	7,971	

MOTOR HEAD ASSEMBLY

The Motor Head Assembly serves as a multi-function tool. This tool was developed to be run primarily with a downhole motor. The Motor Head Assembly combines the coiled tubing connector, dual back pressure valve, and hydraulic disconnect into one compact tool. Utilizing this tool in the bottom hole assembly greatly shortens the overall length of the complete tool string. A shorter bottom hole assembly requires less lubricator, allowing for a much safer rig up of the coiled tubing injector head. The components can also be separated into different configurations depending on specific requirements.

FEATURES

- » Slip Type Connector
- » Dual Flapper Valve
- » Standard Fishing Profile
- » No Exposed Shear Screws

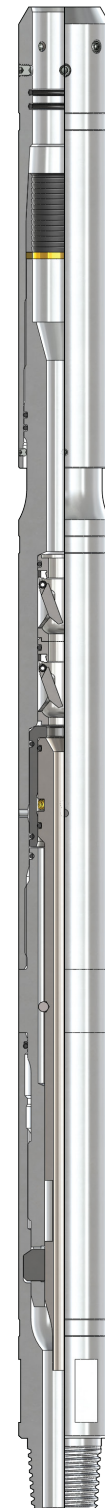

MOTOR HEAD ASSEMBLY

SPECIFICATIONS

COIL O.D.	O.D.	I.D.	LENGTH	OVERPULL	TORQUE	CONNECTION
NOM	in. mm	in. mm	ft. m	lbs. kg	ft-lbs Nm	
1.25	1.70 43.2	0.45 11.5	2.46 0.79	15,000 6,804	625 847	1" AM MT
1.25	2.13 54.0	0.53 13.5	2.95 0.90	60,000 27,216	1,355 1,837	1-1/2" AM MT
1.50	2.13 54.0	0.53 13.5	2.95 0.90	60,000 27,216	1,355 1,837	1-1/2" AM MT
1.50	2.88 73.0	0.69 17.5	3.62 1.10	45,000 20,412	1,500 2,034	2-3/8" PAC
1.75	2.88 73.0	0.69 17.5	3.73 1.14	110,000 49,895	1,200 1,627	2-3/8" PAC
2.00	2.88 73.0	1.00 25.4	3.73 1.14	40,500 18,371	1,000 1,356	2-3/8" PAC

CIRCULATING SUB

The Circulating Sub, normally run above a downhole motor, is designed to provide a means of circulation to the annulus upon activation. This tool utilizes a drop ball for actuation.

FEATURES

- » Saves Wear on Motor
- » Circulating Path
- » Dual Option Available with Rupture Disk

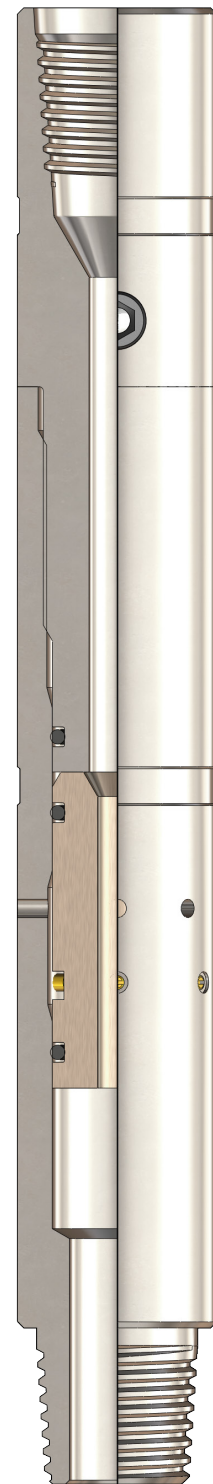

DIVERTING CIRCULATING SUB

SPECIFICATIONS

O.D.	I.D.	LENGTH	OVERPULL	TORQUE	CONNECTION
in.	in.	ft.	lbs.	ft-lbs	
mm	mm	m	kg	Nm	
1.70	0.38	0.83	50,000	459	1" AM MT
43.2	9.5	0.25	22,680	622	
2.13	0.44	1.15	70,630	994	1-1/2" AM MT
53.9	11.1	0.35	32,037	1,348	
2.88	0.56	1.58	174,856	4,489	2-3/8" PAC
73.0	14.3	0.48	79,313	2,626	
3.13	0.59	2.08	223,822	5,879	2-7/8" PAC
79.5	17.5	0.63	101,524	7,971	
4.20	0.81	2.15	324,000	1,650	3-1/2" PH-6
106.7	20.6	0.66	146,964	2,237	

DUAL CIRCULATING SUB

SPECIFICATIONS

O.D.	I.D.	LENGTH	OVERPULL	TORQUE	CONNECTION
in.	in.	ft.	lbs.	ft-lbs	
mm	mm	m	kg	Nm	
1.70	0.38	0.85	50,000	460	1" AM MT
43.2	9.5	0.26	22,680	624	
2.13	0.44	1.17	70,630	994	1-1/2" AM MT
53.9	11.1	0.36	32,037	1,348	
2.88	0.56	1.58	70,630	994	2-3/8" PAC
73.0	14.3	0.48	32,037	1,348	

BEND SUB

The Bend Sub was developed to reduce stress concentrations on critical areas of the BHA. The use of a bend sub will help decrease failure rates due to cyclic stress.

FEATURES

- » Reduces Stress on the BHA
- » Reduce Failure Rates



BEND SUB

SPECIFICATIONS

O.D.	I.D.	LENGTH	OVERPULL	TORQUE	CONNECTION
in.	in.	ft.	lbs.	ft-lbs	
mm	mm	m	kg	Nm	
2.88	1.38	1.50	174,856	4,489	2-3/8" PAC
73.0	35.1	0.46	79,313	6,086	
3.13	1.50	1.48	223,822	5,879	2-7/8" PAC
79.5	38.1	0.45	101,524	7,971	

MAGNET SLEEVE SUB

The Magnet Sub is run above the motor on a milling job to help remove metallic cuttings from the well. The sub uses high strength magnets that attract the metal chips from the wellbore fluid. It is very ideal to use with coiled tubing when annular velocities can be too low to remove cuttings. Once returned to surface, this sub can be easily redressed (debris removed from magnetic catch sleeves) and ready for the next trip in hole.

FEATURES

- » Powerful Magnetic Force for Cutting Removal
- » Easily Redressed



MAGNET SLEEVE SUB

SPECIFICATIONS

O.D.	I.D.	LENGTH	OVERPULL	TORQUE	CONNECTION
in.	in.	ft.	lbs.	ft-lbs	
mm	mm	m	kg	Nm	
2.88	1.13	6.80	158,633	4,489	2-3/8" PAC
73.0	28.7	2.07	71,955	6,086	

LOCKABLE SWIVEL

The Lockable Swivel was designed to allow for long bottom hole assemblies to be made up to the coiled tubing connector. This tool allows for rotation at the swivel instead of rotating the entire bottom hole assembly.

FEATURES

- » Sealed Assembly
- » Torque Thru Capabilities
- » Optional Locking Mechanism

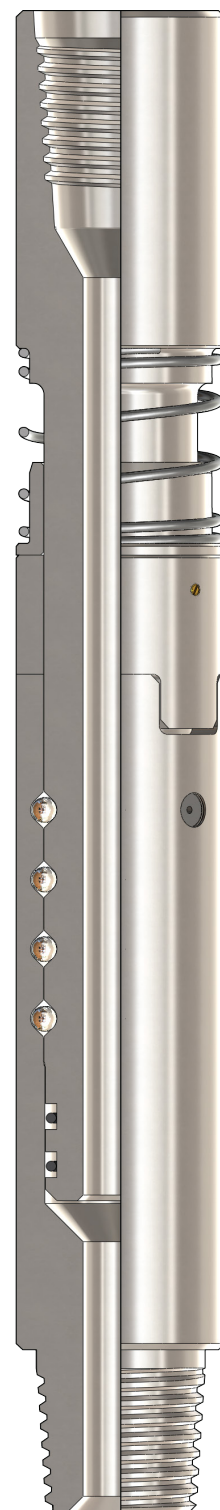

LOCKABLE SWIVEL

SPECIFICATIONS

O.D.	I.D.	LENGTH	OVERPULL	TORQUE	CONNECTION
in.	in.	ft.	lbs.	ft-lbs	
mm	mm	m	kg	Nm	
1.70	0.53	1.30	21,000	418	1" AM MT
43.2	13.5	0.40	9,525	567	
2.13	0.81	1.29	22,300	937	1-1/2" AM MT
54.0	20.6	0.39	10,115	1,270	
2.88	1.00	1.67	59,300	1,760	2-3/8" PAC
73.2	25.4	0.51	26,898	2,386	

SAFETY UNION

The Safety Union was designed to allow for long assemblies to be made up without wrenches overhead, providing for a safer working environment and limiting exposure under the injector head.

FEATURES

- » Safer/Easier Way to Make-Up Tools
- » Eliminates Over-Head Wrenching
- » Limited Time Under Injector Head

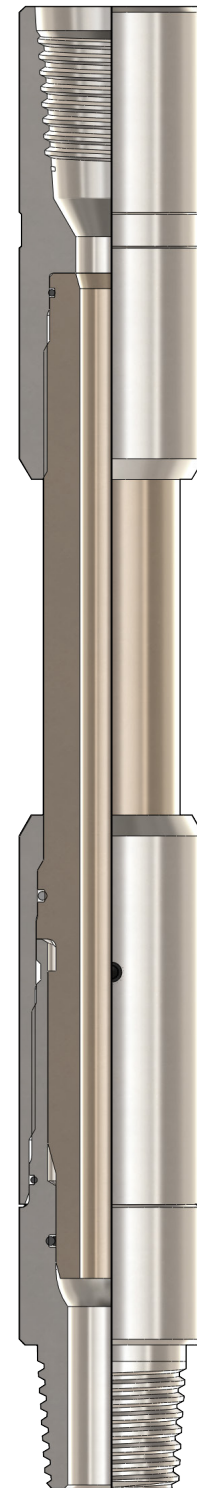

SAFETY UNION

SPECIFICATIONS

O.D.	I.D.	LENGTH	OVERPULL	TORQUE	CONNECTION
in.	in.	ft.	lbs.	ft-lbs	
mm	mm	m	kg	Nm	
2.13	0.75	1.32	62,473	994	1-1/2" AM MT
54.0	19.1	0.40	28,337	1,348	
2.88	1.00	1.72	161,326	5,713	2-3/8" PAC
73.2	25.4	0.52	73,176	7,746	
3.50	1.50	2.34	205,128	7,938	2-7/8" PAC
88.9	38.1	0.71	93,045	10,760	
4.75	2.00	2.67	343,000	8,600	3-1/2" IF
120.7	50.8	0.81	155,582	11,660	

TORQUE-THRU SEALED KNUCKLE JOINT

The Torque-Thru Sealed Knuckle Joint will allow for torque to be transmitted through the tool while providing some flexibility to a rigid bottom hole assembly and reducing any unnecessary side loads. The Knuckle Joint is also sealed to allow fluid to pass through for washing or operating any hydraulic tools below it.

FEATURES

- » Sealed
- » 360 Degree Articulation
- » Torque-Thru Capabilities

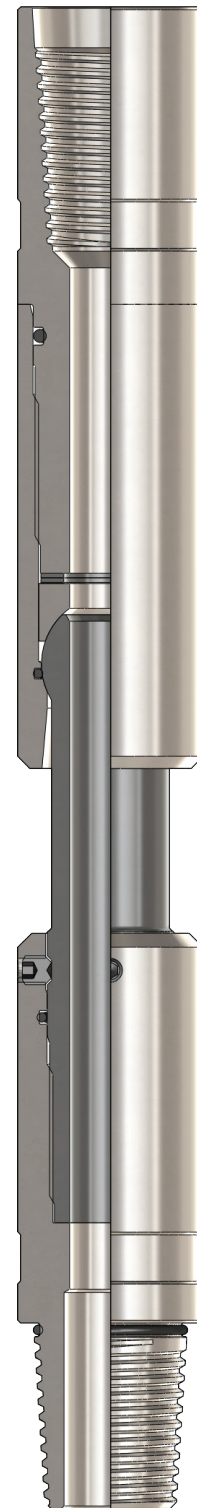

TORQUE-THRU SEALED KNUCKLE JOINT

SPECIFICATIONS

O.D.	I.D.	LENGTH	OVERPULL	TORQUE	CONNECTION
in. mm	in. mm	ft. m	lbs. kg	ft-lbs Nm	
1.70 43.2	0.53 13.5	0.95 0.29	45,000 20,412	308 418	1" AM MT
2.13 54.0	0.59 15.0	1.16 0.35	70,600 32,024	532 721	1-1/2" AM MT
2.88 73.2	0.78 20.0	1.67 0.51	130,991 59,417	1,140 1,546	2-3/8" PAC

NIPPLE LOCATOR

The Nipple Profile Locator gives a simple means of depth location. Run on coiled tubing or slickline, the nipple profile locator gives an overpull when passing through a standard nipple. Depth location can then be correlated back to the coiled tubing counter wheel.

FEATURES

- » Bi-Directional Indication
- » Torque-Thru
- » Flow-Thru



NIPPLE LOCATOR

SPECIFICATIONS

O.D.	I.D.	LENGTH	OVERPULL	TORQUE	CONNECTION
in.	in.	ft.	lbs.	ft-lbs	
mm	mm	m	kg	Nm	
1.70	0.69	1.74	39,280	1,340	1" AM MT
43.2	17.5	0.53	17,817	1,817	
2.13	0.81	2.00	24,800	1,320	1-1/2" AM MT
54.0	20.6	0.61	11,249	1,790	
2.88	0.88	3.08	70,400	4,890	2-3/8" PAC
73.2	22.4	0.94	31,933	6,630	

BOW SPRING CENTRALIZER

The Bow Spring Centralizer is used to centralize the BHA inside larger tubing or casing after it has passed through a restricted ID. The Centralizer is designed for the springs to be at constant maximum expansion.

FEATURES

- » Centralizes Tool String
- » Flow-Thru Capabilities
- » Large Expansion



BOW SPRING CENTRALIZER - MECHANICAL

SPECIFICATIONS

O.D.	I.D.	LENGTH	OVERPULL	TORQUE	CONNECTION
in.	in.	ft.	lbs.	ft-lbs	
mm	mm	m	kg	Nm	
1.70	0.56	3.75	27,920	507	1" AM MT
43.2	14.2	1.14	12,664	687	
2.13	0.56	3.75	33,872	1,043	1-1/2" AM MT
54.0	14.2	1.14	15,364	1,414	
2.88	1.00	4.00	76,792	3,370	2-3/8" PAC
73.0	25.4	1.22	34,832	4,569	

BOW SPRING CENTRALIZER - HYDRAULIC

SPECIFICATIONS

O.D.	I.D.	LENGTH	OVERPULL	TORQUE	CONNECTION
in.	in.	ft.	lbs.	ft-lbs	
mm	mm	m	kg	Nm	
1.70	0.56	4.92	45,280	507	1" AM MT
43.2	14.2	1.50	20,539	687	
2.13	0.56	5.13	79,744	1,043	1-1/2" AM MT
54.0	14.2	1.56	36,171	1,414	
2.88	1.00	5.25	160,640	3,370	2-3/8" PAC
73.0	25.4	1.60	72,865	4,569	

WEIGHT BAR

The use of a weight bar can increase the amount of impact applied at the fish while running in tandem with a Jar and Accelerator.

FEATURES

- » Added Impact While Jarring
- » Custom Made
- » Allows Greater Hammer Effect



WEIGHT BAR

SPECIFICATIONS

O.D.	I.D.	LENGTH	OVERPULL	TORQUE	CONNECTION
in. mm	in. mm	ft. m	lbs. kg	ft-lbs Nm	
1.70 43.2	0.75 19.1	5.00 1.52	50,000 22,680	460 624	1" AM MT
1.70 43.2	0.75 19.1	10.00 3.05	50,000 22,680	460 624	1" AM MT
2.13 54.0	1.00 24.5	5.00 1.52	70,630 32,037	994 1,348	1-1/2" AM MT
2.13 54.0	1.00 24.5	10.00 3.05	70,630 32,037	994 1,348	1-1/2" AM MT
2.88 73.0	1.38 34.9	5.00 1.52	151,184 68,576	1,937 2,626	2-3/8" PAC
2.88 73.0	1.38 34.9	10.00 3.05	151,184 68,576	1,937 2,626	2-3/8" PAC

BOOT BASKET

The Boot Basket is used to collect debris that is too large to be carried out of the hole by normal circulation. The Boot Basket is designed to create a change in velocity around the upper end of the tool, allowing debris to fall into the cavity between the skirt and mandrel.

FEATURES

- » Collects Loose Debris
- » Solid Construction
- » Full Flow-Thru



BOOT BASKET

SPECIFICATIONS

O.D.	I.D.	LENGTH	OVERPULL	TORQUE	CONNECTION
in.	in.	ft.	lbs.	ft-lbs	
mm	mm	m	kg	Nm	
1.70	0.50	2.37	61,400	460	1" AM MT
43.2	12.7	0.72	27,851	624	
2.13	0.50	2.49	88,288	994	1-1/2" AM MT
54.0	12.7	0.76	40,047	1,348	
2.88	0.63	2.51	188,980	1,937	2-3/8" PAC
73.2	16.0	0.77	85,720	2,626	

OVERSHOT

Thru Tubing Solutions specializes in restricted I.D. fishing with a wide assortment of overshots. Sizes range from 1-21/32" to 4-1/8" O.D. (specialty overshots available upon request).

FEATURES

- » Specialty Bowls and Grapples
- » Standard and Oversize Guides
- » Premium Thread Top Subs
- » Series 10, 20, 70 & 150



CONTINUOUS TUBING OVERSHOT

The continuous tubing overshoot is used to retrieve coiled tubing or threaded pipe. This overshoot is a non-releasable tool designed to swallow large sections without dulling grapples.

FEATURES

- » Wide Catch Range
- » Swallow Large Sections of Tubing
- » Coiled Tubing or Threaded Pipe



CONTINUOUS TUBING OVERSHOT

SPECIFICATIONS

O.D.	I.D.	LENGTH	OVERPULL	TORQUE	CATCH RANGE	CONNECTION
in.	in.	ft.	lbs.	ft-lbs	in.	
mm	mm	m	kg	Nm		
1.86	1.31	2.05	25,040	1,010	1" to 1-1/4"	1-1/4" CS
47.2	33.4	0.62	11,358	1,369		
2.06	1.31	2.45	52,000	800	1" to 1-1/4"	1-1/4" CS
52.3	33.4	0.75	23,587	1,085		
2.70	1.81	2.46	49,600	2,250	1" to 1-3/4"	2-3/8" CS
68.6	46.1	0.75	22,498	3,051		
3.13	1.88	2.83	67,200	2,950	1" to 1-3/4"	2-3/8" CS
79.3	47.8	0.86	30,481	4,000		
3.38	2.13	2.64	72,800	4,560	1" to 2"	2-7/8" CS
85.7	53.9	0.80	33,022	6,182		

CUTTING OVERSHOT

The Cutting Overshot is used to cut and retrieve coiled tubing that has been parted, stuck or abandoned in the well bore. Once the appropriate overpull is reached screws are sheared causing the blades to sever the coiled tubing. A clean fishing neck is left looking up.

FEATURES

- » Retrieve Cut Segment
- » Reduced Overpull and Necking of Coil
- » Leaves Clean Cut
- » Coiled Tubing or Threaded Pipe

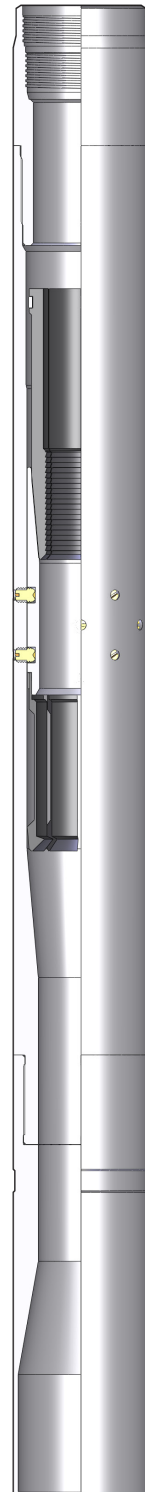

CUTTING OVERSHOT

SPECIFICATIONS

O.D.	I.D.	LENGTH	OVERPULL	TORQUE	CATCH RANGE	CONNECTION
in.	in.	ft.	lbs.	ft-lbs	in.	
mm	mm	m	kg	Nm		
2.06	1.31	1.96	52,000	1,360	1" to 1-1/4"	1-1/2" CS
52.4	33.4	0.60	23,587	1,844		
2.50	1.56	2.98	59,200	2,440	1-1/2"	2-1/16" CS
63.5	39.7	0.91	26,853	3,308		
2.70	1.81	3.25	49,600	2,250	1-1/4" to 1-3/4"	2-3/8" CS
68.6	46.1	0.99	22,498	3,051		
3.38	2.13	2.90	72,800	4,580	1-3/4" to 2"	2-7/8" CS
85.7	53.9	0.88	33,022	6,210		

OVERSHOT PACK-OFF SUB

The Pack-off Sub is designed to be run above the Continuous Tubing or Cutting Overshot. The Pack-off Sub creates a seal between the work string and the fish. Circulation can then be maintained through the fish.

FEATURES

- » Tubing or Coiled Tubing
- » 5000 psi
- » Maintain String Pressure Integrity

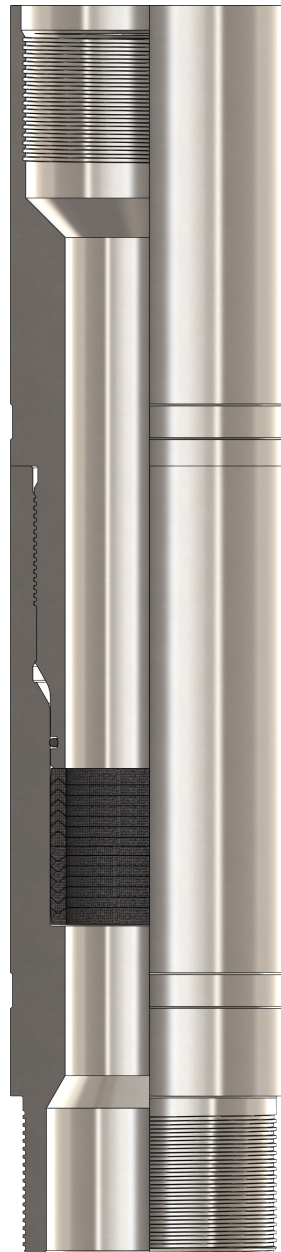

OVERSHOT PACK-OFF SUB

SPECIFICATIONS

O.D.	I.D.	LENGTH	OVERPULL	TORQUE	CATCH RANGE	CONNECTION
in.	in.	ft.	lbs.	ft-lbs	in.	
mm	mm	m	kg	Nm		
1.86	1.30	1.03	55,200	1,010	1" to 1-1/4"	1-1/4" CS
47.2	33.0	0.31	25,038	1,369		
2.06	1.30	1.18	41,600	1,258	1" to 1-1/4"	1-1/4" CS
52.3	33.0	0.36	18,869	1,706		
2.70	1.81	1.30	37,760	2,160	1" to 1-3/4"	2-3/8" CS
68.6	46.1	0.40	17,128	2,929		
3.13	1.81	1.67	72,320	3,890	1" to 1-3/4"	2-3/8" CS
79.3	46.1	0.51	32,804	5,274		
3.38	2.09	1.48	81,600	4,770	1-1/2" to 2"	2-7/8" CS
85.7	53.2	0.45	37,013	6,468		

* Additional sizes available

HYDRA-VAC

The HydraVac is a vacuum bailer tool that works by pumping fluid down the tubing and out the BHA creating a venturi action. This causes suction at the bottom of the tool, pulling debris into the basket where it is trapped. Bailer flapper valves hold the debris until it can be removed from the wellbore. The HydraVac may be run with various lengths of tubing to collect debris as well as different options for the wash over shoe.

FEATURES

- » Removes loose debris
- » Various extension lengths
- » Milling options available

We recommend contacting a Thru Tubing Solutions representative to determine the exact configuration for a given situation.

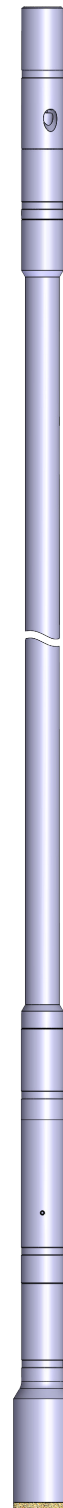

HYDRA-VAC

SPECIFICATIONS

O.D.	LENGTH	OVERPULL	CONNECTION
in.	ft.	lbs.	
mm	m	kg	
2.91	13.07	136,005	2-3/8" PH6
73.9	4.0	61,690	

GS SPEAR

The GS Spear is used to retrieve a device with an internal fishing neck profile. The Spear is designed to withstand high side and tensional loads during a jarring operation. Thru Tubing Solutions utilizes two types of GS spears. Both mechanical and hydraulic spears have special applications depending on well conditions.

FEATURES

- » Continuous Flow-Thru
- » Withstands High Tensile Forces
- » Jar Down to Release (Mechanical)
- » Flow Release Type (Hydraulic)



GS SPEAR - HYDRAULIC TYPE

SPECIFICATIONS

GS PROFILE	O.D.	I.D.	LENGTH	OVERPULL	CONNECTION
NOM	in. mm	in. mm	ft. m	lbs. kg	
2	1.81 46.1	0.19 4.8	2.13 0.65	24,960 11,322	1" AM MT
2-1/2	2.13 53.9	0.25 6.4	2.13 0.65	36,320 16,475	1-1/2" AM MT
3	2.88 73.0	0.25 6.4	2.77 0.84	54,400 24,675	2-3/8" PAC

GS SPEAR - MECHANICAL TYPE

SPECIFICATIONS

GS PROFILE	O.D.	I.D.	LENGTH	CONNECTION
NOM	in. mm	in. mm	ft. m	
2	1.75 44.5	0.19 4.8	0.97 0.30	1" AM MT
2-1/2	2.16 54.9	0.31 7.8	0.99 0.30	1-1/2" AM MT
3	2.88 73.0	0.50 12.7	1.01 0.31	2-3/8" PAC

JDC OVERSHOT

The JDC Overshot is available in both hydraulic and mechanical versions. These tools are used to latch an external fishing neck found on some locks and probes. Utilizing coiled tubing, fluid is pumped through the tool. Sand or debris can then be circulated out of the way, exposing the fishing neck. Once the fishing neck is latched, over-pull is applied. Jars may also be utilized to assist in removing the fish.

FEATURES

- » Hydraulic and Mechanical Versions
- » Withstands High Jar Impacts
- » Pump Through Capabilities



JDC OVERSHOT - HYDRAULIC TYPE

SPECIFICATIONS

GS PROFILE	O.D.	LENGTH	TENSILE	CONNECTION
NOM	in. mm	ft. m	lbs. kg	
2	1.81 46.1	1.76 0.54	31,200 14,152	1" AM MT
2-1/2	2.13 53.9	2.13 0.65	45,400 20,593	1-1/2" AM MT
3	2.88 73.0	2.77 0.84	68,000 30,844	2-3/8" PAC

JDC OVERSHOT - MECHANICAL TYPE

SPECIFICATIONS

GS PROFILE	O.D.	LENGTH	CONNECTION
NOM	in. mm	ft. m	
2	1.88 47.2	1.20 0.37	1" AM MT
2-1/2	2.25 57.2	1.23 0.37	1-1/2" AM MT
3	2.80 71.0	1.25 0.38	2-3/8" PAC

PUMP-THRU WIRE GRAB

The Wire Grab is used as a means of removing lost slickline, electric line, or braided line in the well bore. The barbs on the tool entangle with the lost wire allowing the wire to be retrieved.

FEATURES

- » Retrieve Lost Wireline
- » Pump-Thru

We recommend contacting a Thru Tubing Solutions representative to determine the exact configuration for a given situation.



PUMP-THRU WIRE GRAB

SPECIFICATIONS

O.D.	I.D.	LENGTH	OVERPULL	CONNECTION
in.	in.	ft.	lbs.	
mm	mm	m	kg	
1.70	0.75	2.33	36,800	1" AM MT
43.2	19.1	0.71	16,692	
2.13	0.75	2.47	51,120	1" AM MT
54.0	19.1	0.75	23,188	
2.25	0.75	2.48	81,280	1" AM MT
57.2	19.1	0.76	36,868	
2.88	1.00	2.67	70,630	1-1/2" AM MT
73.2	1.38	3.23	32,037	
3.25	1.38	3.23	174,856	2-3/8" PAC
82.6	35.1	0.98	79,313	
3.63	1.38	3.15	151,184	2-3/8" PAC
92.2	34.9	0.96	68,576	
4.50	1.38	3.25	151,184	2-3/8" PAC
114.2	34.9	0.99	68,576	

PUMP-THRU ROPE SPEAR

The Rope Spear is used as a means of removing lost slickline, electric line, or braided line in the well bore. The barbs on the tool entangle with the lost wire allowing the wire to be retrieved.

FEATURES

- » Retrieve Lost Wireline
- » Pump-Thru

We recommend contacting a Thru Tubing Solutions representative to determine the exact configuration for a given situation.



PUMP-THRU ROPE SPEAR

SPECIFICATIONS

O.D.	I.D.	LENGTH	OVERPULL	CONNECTION
in.	in.	ft.	lbs.	
mm	mm	m	kg	
1.88	0.38	3.51	35,590	1" AM MT
47.8	9.7	1.07	16,143	
2.13	0.50	3.80	43,402	1-1/2" AM MT
54.0	12.7	1.16	19,687	
2.25	0.50	3.80	43,402	1-1/2" AM MT
57.2	12.7	1.16	19,687	
2.88	0.75	3.80	106,000	2-3/8" PAC
73.0	19.1	1.16	48,081	
3.50	0.75	3.80	106,000	2-3/8" PAC
88.9	19.1	1.16	48,081	
4.50	0.75	3.80	106,000	2-3/8" PAC
114.3	19.1	1.16	48,081	

DEPLOYMENT BAR

The deployment bar is used to deploy long bottom hole assemblies into and out of the well. A deployment bar in the bottom hole assembly allows the capability of closing the BOP rams and slips for adding or removing a segment of the bottom hole assembly. This limits the amount of lubricator needed.

FEATURES

- » Deploy Long Bottom Hole Assemblies
- » O.D. to Match Coil O.D.

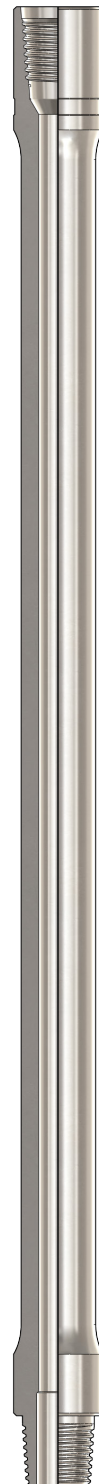

DEPLOYMENT BAR

SPECIFICATIONS

DEP. O.D.	O.D.	I.D.	LENGTH	OVERPULL	TORQUE	CONNECTION
in.	in. mm	in. mm	ft. m	lbs. kg	ft-lbs Nm	
1.25	1.70 43.2	0.75 19.1	10.00 3.05	50,000 22,680	460 624	1" AM MT
1.50	1.70 43.2	0.75 19.1	10.00 3.05	50,000 22,680	460 624	1" AM MT
1.25	2.13 54.0	0.75 19.1	10.00 3.05	70,630 32,037	944 1,280	1-1/2" AM MT
1.50	2.13 54.0	0.75 19.1	10.00 3.05	56,540 25,540	994 1,280	1-1/2" AM MT
1.75	2.13 54.0	0.75 19.1	10.00 3.05	70,630 32,037	994 1,280	1-1/2" AM MT
2.00	2.13 54.0	0.75 19.1	10.00 3.05	70,630 32,037	994 1,280	1-1/2" AM MT
1.50	2.88 73.0	1.00 28.7	10.00 3.05	86,429 39,204	2,814 3,815	2-3/8" PAC
1.75	2.88 73.0	1.00 28.7	10.00 3.05	142,607 64,685	4,489 6,086	2-3/8" PAC
2.00	2.88 73.0	1.00 35.1	10.00 3.05	174,856 79,313	4,489 6,086	2-3/8" PAC
2.38	2.88 73.0	1.25 31.8	10.00 3.05	174,856 79,313	4,489 6,086	2-3/8" PAC
2.63	2.88 73.0	1.38 35.1	10.00 3.05	174,856 79,313	4,489 6,086	2-3/8" PAC
2.38	3.13 79.3	1.50 38.1	10.00 3.05	223,821 101,523	5,879 7,971	2-7/8" PAC
2.63	3.13 79.3	1.50 38.1	10.00 3.05	223,821 101,523	5,879 7,971	2-7/8" PAC

PUMP-OFF CHECK VALVE

The Pump-Off Check Valve was developed primarily for the snubbing and workover industry. This tool allows for circulating sand and solids while tripping tubing in the hole under pressure. Upon landing tubing at surface, a ball is dropped and pumped down to the tool. This causes the aluminum insert locking mechanism to shear and release. Once released a full I.D. is left in the production tubing.

FEATURES

- » Drop Ball for Actuation
- » Flapper or Ball Check Valve
- » Aluminum Insert
- » Standard Tubing Connections

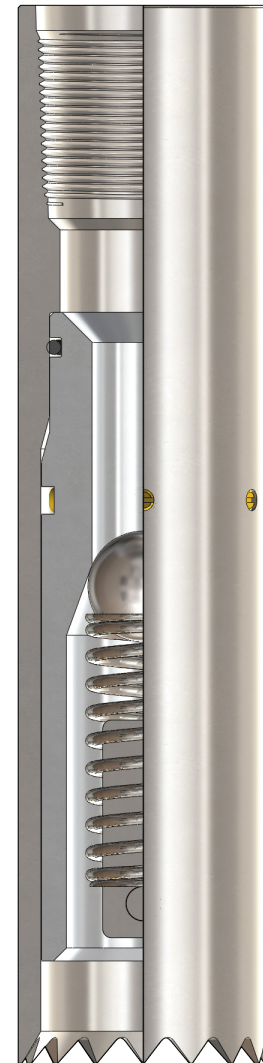

PUMP-OFF CHECK VALVE

SPECIFICATIONS

O.D.	LENGTH	OVERPULL	TORQUE	CONNECTION
in.	ft.	lbs.	ft-lbs	
mm	m	kg	Nm	
3.06	1.02	114,769	2,975	2-3/8" 8 Rd
77.8	0.31	52,058	4,034	
3.06*	1.02	167,200	3,813	2-3/8" 8 Rd
77.8	0.31	75,841	5,170	
3.06	1.02	167,200	1,900	2-3/8" CS
77.8	0.31	75,841	2,576	
3.68	1.29	244,000	2,975	2-7/8" 8 Rd
93.3	0.39	110,677	4,034	

* Flapper Style Check Valve I.D. - 0.97 in. (24.6 mm)

PUMP-OFF BIT SUB

The Pump-Off Bit Sub was developed for the Snubbing and Workover Industry. This tool is used in conjunction with a Bit or Mill to complete a workover operation. Upon completing the drilling operation and landing the tubing at surface, a ball is dropped and or pumped to the tool. As a result, pressure is generated causing the locking mechanism to shear and release. The bottom sub then separates and the well is ready for production.

Thru Tubing Solutions offers four different styles of bit sub: single flapper, double flapper, ball check and reverse circulating.

FEATURES

- » Drop Ball for Actuation
- » Flapper or Ball Check Valve
- » Aluminum Insert
- » Standard Tubing Connections



PUMP-OFF BIT SUB w/ BALL CHECK VALVE

SPECIFICATIONS

O.D.	LENGTH	OVERPULL	TORQUE	CONNECTION
in.	ft.	lbs.	ft-lbs	
mm	m	kg	Nm	
2.20	1.29	40,000	994	1-1/4" 10 Rd Box x 1-1/2" AM MT Box
55.9	0.39	18,144	1,348	
3.13	1.85	63,200	2,830	2-3/8" 8 Rd Box x 2-3/8" REG Box
79.4	0.56	28,667	3,837	
3.68	1.96	104,966	2,975	2-3/8" 8 Rd Box x 2-7/8" REG Box
93.5	0.60	47,612	4,034	
3.68	1.96	104,966	3,813	2-7/8" 8 Rd Box x 2-7/8" REG Box
93.5	0.60	47,612	5,170	

PUMP-OFF BIT SUB w/ SINGLE FLAPPER

SPECIFICATIONS

O.D.	I.D.	LENGTH	OVERPULL	TORQUE	CONNECTION
in.	in.	ft.	lbs.	ft-lbs	
mm	mm	m	kg	Nm	
3.06	0.97	1.81	63,200	2,830	2-3/8" 8 Rd Box x 2-3/8" REG Box
77.8	24.6	0.55	28,667	3,837	
3.13	0.97	1.81	63,200	2,830	2-3/8" 8 Rd Box x 2-3/8" REG Box
79.4	24.6	0.55	28,667	3,837	
3.68	0.97	1.96	84,000	2,975	2-3/8" 8 Rd Box x 2-7/8" REG Box
93.5	24.6	0.60	38,102	4,034	
3.68	0.97	1.96	84,000	3,810	2-7/8" 8 Rd Box x 2-7/8" REG Box
93.5	24.6	0.60	38,102	5,166	
3.68	0.97	2.00	198,400	2,450	2-7/8" PH-6 Box x 2-7/8" REG Box
93.5	24.6	0.61	89,993	3,322	

SAFETY JOINTS

Safety Joints are designed for high bending flexibility. They are manufactured with a proprietary thread designed to prevent unwanted back-off failures. Stress reliefs in the tools minimize bending loads on the break point allowing high flexibility.

FEATURES

- » Requires Less Torque
- » Flow-Thru



SAFETY JOINTS

SPECIFICATIONS

O.D.	I.D.	LENGTH	OVERPULL	TORQUE	CONNECTION
in.	in.	ft.	lbs.	ft-lbs	
mm	mm	m	kg	Nm	
3.46	2.26	5.73	191,498	4,400	2-7/8" PH-6, 7.90 lb / ft
87.9	57.4	1.75	86,862	5,966	
3.52	2.20	5.69	218,400	4,400	2-7/8" PH-6, 8.70 lb / ft
89.4	55.9	1.73	99,065	5,966	

SLIDING SLEEVE BIT SUB

The Sliding Sleeve Bit Sub was developed for the Snubbing and Workover Industry. This tool is used in conjunction with a Bit or Mill to complete a workover operation. Upon completing the drilling operation and landing the tubing at surface, a ball is dropped and or pumped to the tool. As a result, pressure is generated causing the sleeve mechanism to shear. The inner sleeve shifts down, exposing ports and the well is ready for production without pumping anything into the bottom of the well.

FEATURES

- » Drop Ball for Actuation
- » Torque-Thru
- » Balanced Piston
- » Standard Connections
- » High Tensile Strength



SLIDING SLEEVE BIT SUB

SPECIFICATIONS

O.D.		LENGTH	OVERPULL	TORQUE	CONNECTION
in.		ft.	lbs.	ft-lbs	
mm		m	kg	Nm	
3.13		2.56	148,938	3,709	2-3/8" 8 Rd Box x 2-3/8" REG Box
79.5		0.78	67,557	5,029	
3.67		1.88	159,456	3,049	2-7/8" 8 Rd Box x 2-7/8" REG Box
93.2		0.57	72,328	4,134	
3.67		2.44	159,456	3,232	2-7/8" 8 Rd Box x 2-3/8" REG Box
93.2		0.74	72,328	4,382	
3.67		2.90	159,456	3,049	2-7/8" 8 Rd Box x 2-7/8" REG Box
93.2		0.88	72,328	4,134	
3.67		2.83	148,938	3,232	2-3/8" 8 Rd Box x 2-3/8" REG Box
93.2		0.86	67,557	4,382	
3.67		1.83	109,552	2,975	2-3/8" 8 Rd Box x 2-7/8" REG Box
93.2		0.56	49,692	4,034	

SNUBBING BACK PRESSURE VALVE

The Snubbing Back Pressure Valve was designed to provide a dependable method of well control. This tool is typically run close to the bottom of the string to prevent fluid or gas from entering the tubing string. The dual flappers allow for a ball to pass through the tool and are more reliable than old style ball checks or dart-type floats.

FEATURES

- » Dual Flappers
- » Two Piece Construction
- » Teflon Seats
- » Standard and Premium Connections
- » No Ball and Seats to Wash Out



SNUBBING BACK PRESSURE VALVE

SPECIFICATIONS

O.D.	I.D.	LENGTH	OVERPULL	TORQUE	CONNECTION
in.	in.	ft.	lbs.	ft-lbs	
mm	mm	m	kg	Nm	
1.60	0.58	1.08	56,000	500	1" CS
40.6	14.7	0.33	25,401	678	
1.93	0.69	1.34	80,000	800	1-1/4" CS
49.0	17.5	0.41	36,287	1,085	
2.18	1.00	1.42	96,000	1,000	1-1/2" CS
55.3	25.4	0.43	43,545	1,356	
2.33	1.00	1.42	82,400	1,100	2-1/16" CS
59.2	25.4	0.43	37,376	1,491	
2.92	1.00	1.72	189,600	3,400	2-3/8" PH-6
74.3	25.4	0.52	86,001	4,610	
3.51	1.00	1.91	268,800	6,060	2-7/8" PH-6
89.2	24.6	0.58	121,926	8,216	
4.31	1.00	1.57	324,000	8,800	3-1/2" PH-6
109.5	25.4	0.48	146,964	11,930	
2.19	0.69	1.09	99,000	1,579	1-1/4" REG
55.6	17.5	0.33	44,906	2,141	
3.13	1.00	1.78	230,602	5,400	2-3/8" REG
79.4	25.4	0.54	104,599	7,321	
3.06	1.00	1.78	148,938	3,709	2-3/8" 8 Rd
77.8	25.4	0.54	67,557	5,029	
3.67	1.00	2.00	218,584	3,991	2-7/8" 8 Rd
93.2	25.4	0.61	99,148	5,411	
4.75	1.00	1.40	430,694	1,281	3-1/2" IF
120.7	25.4	0.43	195,360	1,737	

RELIEF VALVE

The Relief Valve is designed to safely bleed pressure from below a lock or back pressure valve. The plunger breaks the seal of a flapper style check valve as it is threaded into the main housing. The relief valve can be retro-fitted to accommodate any TTS flapper type back pressure valve.

FEATURES

- » Safe Means of Relieving Pressure
- » Jam Nut Pressure Seal
- » Large By-Pass Area

We recommend contacting a Thru Tubing Solutions representative for determining the exact configuration for a given situation.

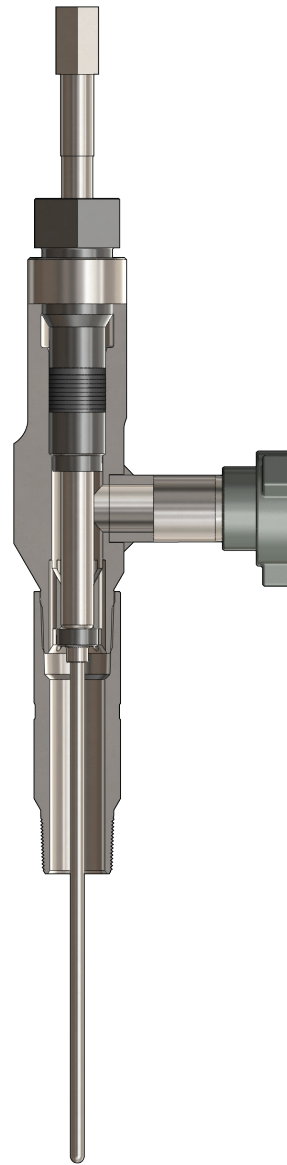

PROFILE NIPPLE

Thru Tubing Solutions has a wide variety of both tubing and drill pipe nipples. We specialize in high pressure dual flapper style locks. Contact a TTS representative for profile and plug specifications and recommendations.

FEATURES

- » 8 Round and Premium Threads
- » Drill Pipe Connections
- » Wide Range of Profiles

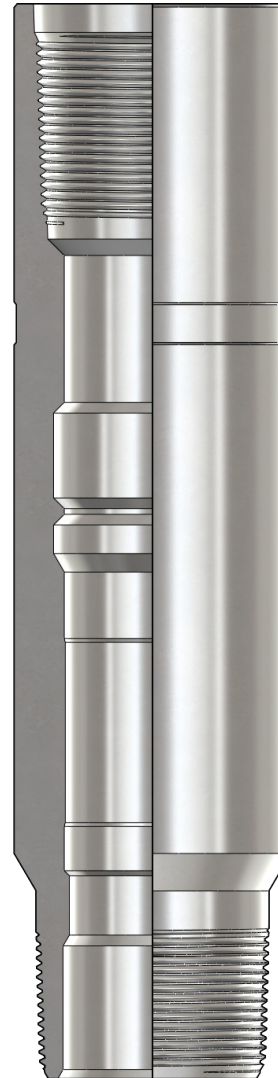

PROFILE NIPPLE

SPECIFICATIONS

SIZE & PROFILE	SEAL BORE		NO GO I.D.	
	in.	mm	in.	mm
NOM				
1.710 'R' / 'RN'	1.710	43.4	1.560	39.6
2.125 'R' / 'RN'	2.125	53.8	1.937	49.2
2.188 'R' / 'RN'	2.188	55.6	2.010	51.1
2.313 'R' / 'RN'	2.313	58.7	2.131	54.1
2.563 'R' / 'RN'	2.563	65.1	2.329	59.2
1.500 'X' / 'XN'	1.500	38.1	1.448	36.8
1.875 'X' / 'XN'	1.875	47.6	1.791	45.5
2.313 'X' / 'XN'	2.313	58.7	2.205	56.0

PUMP-THRU LOCK

The Pump-Thru Lock is used primarily in the Snubbing industry and provides the capability of setting, changing or removing flow control equipment such as a Slickline Back Pressure Valve. It utilizes locking keys that provide a positive anchor within a nipple profile. This tool can either be run in place or set and pulled via slickline. The Pump-Thru Lock relies on a standard nipple profile and is capable of handling many hours of continuous pumping.

FEATURES

- » Slickline Set and Retrieved
- » Utilizes Standard Nipple Profiles
- » Equalizing Feature
- » Dual Flappers



PUMP-THRU LOCK

SPECIFICATIONS

SIZE & PROFILE	NO GO O.D.	MIN I.D.	EQ. FLOW AREA
NOM	in. mm	in mm	in ² cm ²
1.710 'R' / 'RN'	1.700 43.2	0.57 14.5	0.49 0.32
2.125 'R' / 'RN'	2.115 53.7	0.69 17.5	0.28 0.18
2.188 'R' / 'RN'	2.175 55.2	0.69 17.5	0.49 0.32
2.313 'R' / 'RN'	2.300 58.4	0.69 17.5	0.49 0.32
2.563 'R' / 'RN'	2.550 64.8	1.00 25.4	0.41 0.26
1.500 'X' / 'XN'	1.490 37.8	0.57 14.5	0.14 0.09
1.875 'X' / 'XN'	1.865 47.4	0.69 17.5	0.28 0.18
2.313 'X' / 'XN'	2.300 58.4	0.69 17.5	0.14 0.09

ROLL-ON CONNECTOR

The coiled tubing roll-on connector is used as a simple means of connecting the coiled tubing to a bottom hole assembly. The roll-on connector is attached to the coiled tubing by a method known as “crimping” the OD of the coiled tubing.

The coiled tubing roll-on connector is available in a variety of coiled tubing O.D. and weight configurations. The connectors may also be customized to meet your specifications.

FEATURES

- » Keeps BHA Same O.D. as Coil
- » Simple Installation



ROLL-ON CONNECTOR

SPECIFICATIONS

COIL O.D.	O.D.	I.D.	LENGTH	CONNECTION
in.	in. mm	in. mm	ft. m	
1.25	1.25 31.8	0.63 16.0	0.13 0.04	7/8" AM MT
1.50	1.50 38.1	0.75 19.1	0.15 0.05	1" AM MT
1.75	1.75 44.5	0.75 19.1	0.15 0.05	1" AM MT
1.75	1.94 49.3	1.00 25.4	0.15 0.05	1-1/2" AM MT
2.00	2.00 50.8	1.00 25.4	0.17 0.05	1-1/2" AM MT
2.38	2.38 60.3	1.00 25.4	0.54 0.16	1-1/2" AM MT

BACK PRESSURE VALVE

The coiled tubing back pressure valve is run as a down hole safety valve, preventing the flow upward inside of the coiled tubing string. All of the internal components are replaceable, allowing for simple redress of the complete back pressure valve.

The coiled tubing back pressure valve is also available in a variety of different styles and may also be customized to meet your specifications.

FEATURES

- » Replaceable Inserts
- » Dual Flappers
- » AM MT and Mini MT Connections
- » Can Accommodate Downhole Screen



BACK PRESSURE VALVE - FLAPPER TYPE

SPECIFICATIONS

O.D.	I.D.	LENGTH	OVERPULL	TORQUE	CONNECTION
in.	in.	ft.	lbs	ft-lbs	
mm	mm	m	kg	Nm	
1.25	0.47	0.88	22,081	254	7/8" AM MT
31.8	11.9	0.27	10,016	344	
1.50	0.58	1.08	38,180	460	1" AM MT
38.1	14.7	0.33	17,318	624	
1.75	0.69	1.03	50,000	460	1" AM MT
44.5	17.5	0.31	22,680	624	
2.00	1.00	1.17	53,273	898	1-1/2" AM MT
50.8	25.4	0.36	24,164	1,218	

BACK PRESSURE VALVE - BALL TYPE

SPECIFICATIONS

O.D.	LENGTH	OVERPULL	TORQUE	CONNECTION
in.	ft.	lbs	ft-lbs	
mm	m	kg	Nm	
1.25	0.59	27,601	327	7/8" AM MT
31.8	0.18	12,520	443	
1.50	0.61	62,500	460	1" AM MT
38.1	0.19	28,350	624	
1.75	0.62	50,000	460	1" AM MT
44.5	0.19	22,680	624	
2.00	0.93	70,630	994	1-1/2" AM MT
50.8	0.28	32,037	1,348	

SEALED KNUCKLE JOINT

The coiled tubing sealed knuckle joint is used as a simple point of flexibility in a rigid bottom hole assembly. Having this component in the tool string maintains a sealed bottom hole assembly, yet allows for movement below the knuckle joint.

FEATURES

- » 360 Degree Articulation
- » High Tensile

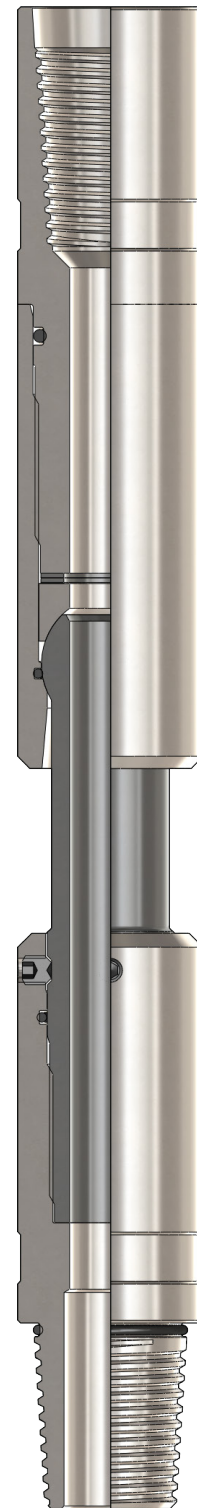

SEALED KNUCKLE JOINT

SPECIFICATIONS

O.D.	I.D.	LENGTH	OVERPULL	CONNECTION
in.	in.	ft.	lbs	
mm	mm	m	kg	
1.25	0.44	0.86	22,081	7/8" AM MT
31.8	11.2	0.26	10,016	
1.50	0.50	1.01	34,914	1" AM MT
38.1	12.7	0.31	15,837	
1.75	0.50	1.10	21,000	1" AM MT
44.5	12.7	0.34	9,525	
2.00	0.88	1.35	49,600	1-1/2" AM MT
50.8	22.2	0.41	22,498	

WASH NOZZLE

The coiled tubing wash nozzle is used to clean the inside of well tubulars. While flowing through the wash nozzle a jetting action occurs allowing for the removal of fill from within the well bore. Selecting the appropriate nozzle configuration along with appropriate velocity at the nozzle, allows removal of residue such as salt, sand, mud, rust, and scale from the well bore.

FEATURES

- » High Velocity Nozzles
- » Variety of Port Angles and Sizes

The coiled tubing wash nozzle is available in many configurations. The nozzles may also be customized to meet your specifications. We recommend contacting a Thru Tubing Solutions representative for determining the exact tool for a given situation.

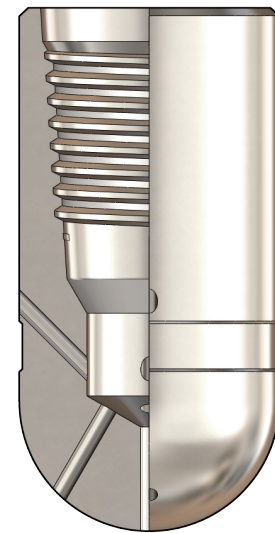

WASH NOZZLE

SPECIFICATIONS

O.D.		LENGTH	CONNECTION
in.	mm		
		ft.	
		m	
1.25	31.8	0.19	7/8" AM MT
		0.06	
1.50	38.1	0.28	1" AM MT
		0.09	
1.75	44.5	0.29	1" AM MT
		0.09	
2.00	50.8	0.29	1-1/2" AM MT
		0.09	
2.13	53.9	0.42	1-1/2" AM MT
		0.13	
2.88	73.0	0.71	2-3/8" PAC
		0.22	

PUMP-OFF WASH NOZZLE

The pump-off wash nozzle allows for washing debris, such as sand and solids while circulating the well bore. This tool utilizes a ball check valve that prevents flow into the coiled tubing string. Upon landing the string at the appropriate depth, a ball is pumped down to the tool activating the release mechanism. All of the internal components are then pumped out leaving the coiled tubing ready for production.

FEATURES

- » Balanced Piston
- » High Velocity Nozzle
- » Positive Lock Mechanism

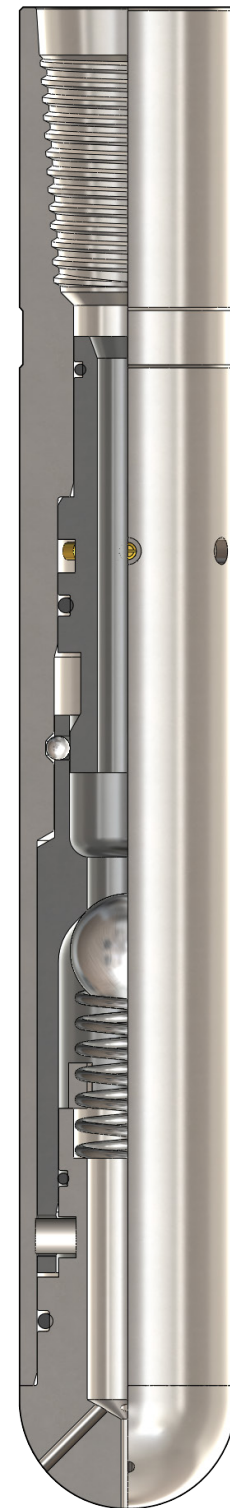

PUMP-OFF WASH NOZZLE - BALL TYPE

SPECIFICATIONS

O.D.	LENGTH	OVERPULL	TORQUE	CONNECTION
in.	ft.	lbs	ft-lbs	
mm	m	kg	Nm	
1.25	0.69	27,601	327	7/8" AM MT
31.8	0.21	12,520	443	
1.50	0.77	50,000	460	1" AM MT
38.1	0.23	22,680	624	
1.75	1.07	62,500	460	1" AM MT
44.5	0.33	28,350	624	
2.00	1.16	70,630	994	1-1/2" AM MT
50.8	0.35	32,037	1,348	

PUMP-OFF WASH NOZZLE - DUAL FLAPPER

SPECIFICATIONS

O.D.	LENGTH	OVERPULL	TORQUE	CONNECTION
in.	ft.	lbs	ft-lbs	
mm	m	kg	Nm	
1.50	1.01	23,780	334	1" AM MT
38.1	0.31	52,426	453	
2.12	1.41	88,288	994	1-1/2" AM MT
53.8	0.43	40,047	1,348	

SPINNING WASH TOOL

The Spinning Wash Tool was developed specifically for Coiled tubing down hole operations. This tool features a nozzle head that rotates by means of water jet reaction force. Its rotational speed is controlled by a high-pressure water swivel with a viscous brake. The water jets were designed to clean irregular surfaces without damaging tubular goods. The Spinning Wash Tool is used to clean Calcium Carbonate Scale, Barium Sulfate Scale, Water Scale, Asphaltine and paraffin plugs.

FEATURES

- » Self Rotating
- » Interchangeable Heads
- » Stainless Steel Construction
- » Standard Connections
- » Controlled Viscous Brake



SPINNING WASH TOOL

SPECIFICATIONS

O.D.		LENGTH	FLOW RANGE	CONNECTION
in.	ft.		bpm	
mm	m		Lpm	
1.69	0.82		0.7 - 1.3	1" AM MT
42.9	0.24		111 - 207	
2.13	1.33		0.8 - 2.0	1-1/2" AM MT
53.9	0.41		127 - 318	
2.50	1.33		1.0 - 3.0	1-1/2" AM MT
63.5	0.41		160 - 480	
2.87	1.30		1.0 - 3.0	2-3/8" PAC
73.0	0.39		160 - 480	

SURFACE BULKHEAD

The E-Coil Surface Bulkhead is used to terminate the logging cable inside the reel on an e-coil coiled tubing unit. This device provides a high pressure, fluid-tight point for the logging conductors to transition from the inside of the coiled tubing to the cable going to the collector ring.

FEATURES

- » Rated to 15,000 PSI
- » Single or Multi-Conductor Cable

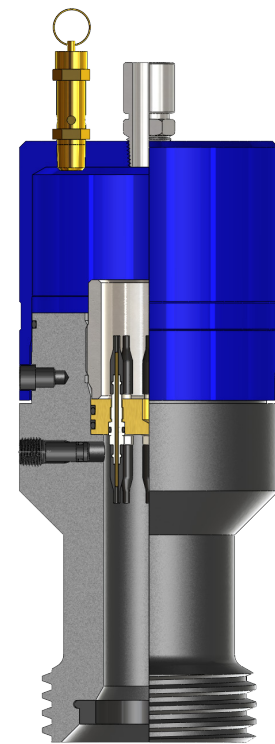

CABLEHEAD

The E-Coil Cablehead is intended for coiled tubing logging applications by providing a connector or crossover between the coiled tubing and the logging tools. It is designed with a shock-mounted shear pin disconnect, which serves as an emergency release in case the logging tools become stuck while in the well. This tool also incorporates a cable bypass sub that includes two flapper check valves to prevent flow back up the coiled tubing.

FEATURES

- » Proprietary Shock-Absorption System
- » Single or Multi-Conductor Cable
- » Full Pressure Control
- » Available in 1.75" and 2.88" OD



CABLEHEAD

SPECIFICATIONS

O.D.		LENGTH	TYPE	CONNECTION
in.	mm			
1.75	44.5	3.02	SINGLE	1" AM MT Box x 1.69" Type "A" Go Pin
		0.92		
2.88	73.0	3.56	SINGLE	2-3/8" PAC Box x 2.00" Type "A" Go Pin
		1.09		
2.88	73.0	3.41	MULTI	2-3/8" PAC Box x 2.00" - 8 Stub Acme Box
		1.04		

SLIC FRAC

SlicFrac is a patented diverter technology that selectively diverts the stimulation treatment to untreated formation, efficiently increasing the stimulated reservoir volume. Incorporating Perf PODs mid-stage provides effective diversion from the previously stimulated perforations, allowing breakdown of additional clusters. By replacing frac plugs and extending the stage lengths, TTS is able to provide a more economical solution with a better fracture stimulation.

Perf PODs are perforation plugging devices that can be deployed in a wellbore to efficiently attach to and block perforations; sealing irregularly shaped holes. Perf PODs are available as millable, degradable or acid resistant and can be mechanically removed with a standard milling BHA. Deployed from surface, PODs are launched during the flush portion of the frac to divert flow, isolate perfs and provide subsequent breakdown of additional clusters. The Wireline (WL) POD Tool is used to deploy PODs downhole below the perf guns, essentially replacing the frac plug and isolating lower perforations.

Perf PODs have a 10k psi differential pressure rating, in varying perf sizes. The PODs provide an excellent solution for both re-completions and new completions alike.

SlicFrac is the ideal solution for the following applications:

- » New Completions
- » Re-Completions/Re-Fracs
- » Diversion
- » Casing Damage
- » Lost Circulation
- » Chemical Diversion

FEATURES

- » Reduce/Eliminate Bridge Plugs
- » Eliminate CT Cleanouts
- » Reduce Water Usage
- » Eliminate Down Time between Fracs
- » Reduce Overall Completion Time
- » Increase Frac Efficiency
- » Increase Reservoir Contact
- » Increase Production



E-WRENCH

The E-Wrench is a portable torque measurement system which comes complete with a 7" Android tablet ready for use on location. The E-Wrench provides traceability for the make-up of tubing conveyed bottom hole assemblies to ensure tools are run according to specifications. Audio and visual cues indicate when the targeted torque is reached, preventing over and under torquing the downhole tools.

The E-Wrench software is compatible with most Android, Bluetooth enabled devices and works in conjunction with the E-Wrench. The software allows for torque curves to be uploaded to a database or printed remotely from the table to a Bluetooth enabled printer, providing a permanent record of each torqued connection.

The TTS Jaw Locking System enables the E-Wrench to grip the tools securely while making and breaking joints. This patent pending safety feature allows a single operator to perform these tasks and reduces the tendency of the wrenches to reactively bounce off the tool during breakout.

A water tight chamber and vibration isolation grommets keep the electronics well protected, making the E-Wrench suitable for harsh oilfield conditions.

FEATURES

- » Eliminates Over and Under Torquing
- » Durable Construction
- » Features TTS "Jaw Locking System"
- » Quality Tested and Inspected

AVAILABLE IN

- » 36" Pipe Wrench
- » 48" Pipe Wrench
- » 2.88" OD Petol Wrench
- » 2-7/8" AOT Kelco K-25 Wrench

An intrinsically safe model and additional E-Wrench sizes are available upon request. We recommend contacting a Thru Tubing Solutions' representative for your specific needs.



E-VISE

This revolutionary product provides safe, accurate torque measurement in a versatile, compact design that accommodates virtually any shop environment. The E-Vise is compatible with existing vises and wrenches—no special tools are required for setup. Wireless bluetooth connection to a Windows-compatible machine provides simple audio and visual cues to prevent over and under torquing equipment.

FEATURES

- » Easy to Install
- » No Hard-wire Connection Needed
- » Easy to Use
- » Records Data



CHEMICALS

Thru Tubing Solutions' proprietary line of chemicals was designed for coil tubing and stick pipe applications. Each product is engineered to provide a premium chemical makeup that optimize downhole operations. TTS offers a variety of chemicals in the form of friction reducers, gels, lubricants, scale inhibitors, biocide, sulfide scavenger, and oxygen scavenger.

We recommend contacting a TTS representative to find the best chemical for your operation.

FEATURES

- » TriboSlick® Series (Lubricant, Pipe-on-Pipe)
- » RheoSlick® Series (Turbulent Drag Reducer (FR))
- » ViscoSweep® Series (Gel)
- » TriboSphere™ (Beads)
- » ChromaSweep™ (Dye)



MILLING ASSEMBLY

TTS' rugged milling BHA is designed to withstand the demanding side loading stresses associated with working in horizontal wells. From top to bottom, this tool string was engineered to reach TD.

System Components

- » Coiled Tubing Connector
- » Back Pressure Valve
- » HydraSet Jar
- » Hydraulic Disconnect
- » Circulating Sub
- » WavForce XRV
- » Titan Motor
- » Carbide Mill

FEATURES

- » Versatile BHA Components
- » Proprietary Equipment
- » Rugged Design



BYPASSING PERFORATING SYSTEM

The patented Bypassing Perforator allows the operation of tools below the perforator, the perforator itself, and then below the perforator again in a single run. This system is typically run with a motor for toe prep operations to provide a means of milling/cleaning to bottom prior to and after perforating.

System Components

- » Coiled Tubing Connector
- » Back Pressure Valve
- » Hydraulic Disconnect
- » Bypassing Perforator
- » Titan Motor
- » Carbide Mill

FEATURES

- » Single Trip Flow-Thru/Perforate/Flow-Thru
- » Proven Perforating Technology

